

# CPTC Thermistor: PL Series

## For Switching Application



### ■ Features

1. RoHS compliant
2. For lighting applications
3. For frequent switching
4. Small size
5. Low, medium and high resistance ratings
6. Delay time are ratings
7. Stable over a long life
8. Operating temperature range : 0 ~ +60°C (V=Vmax)  
-25 ~ +125°C (V=0)

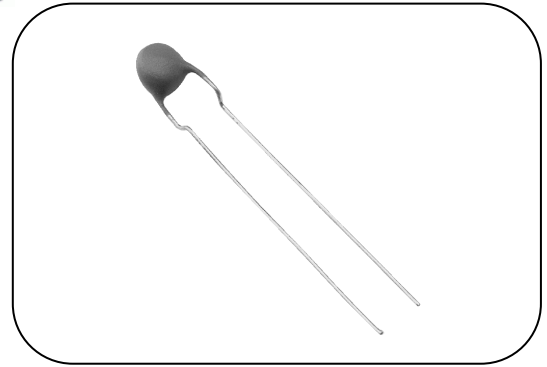

### ■ Recommended Applications

1. Electronic ballast for lamps, switching

### ■ Part No. Code

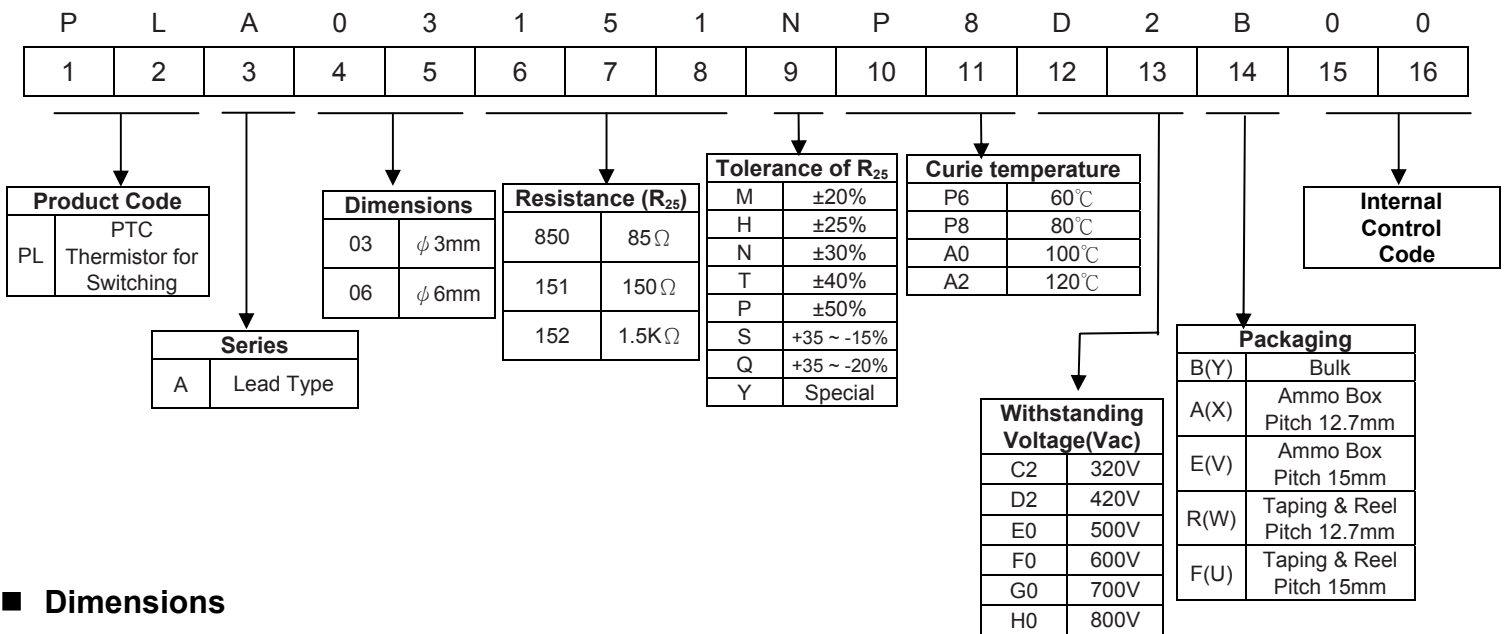

### ■ Dimensions

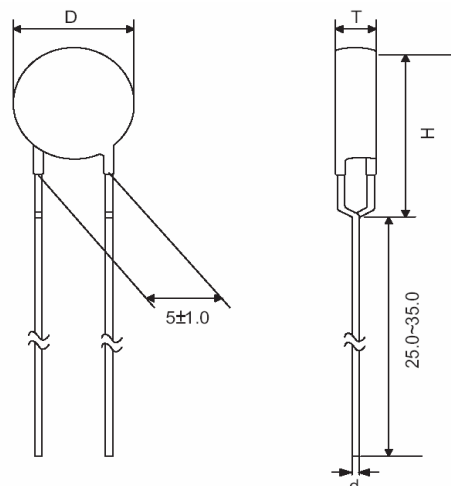

(Unit: mm)

Note:  
The code in ( ) is for RoHS control.

# CPTC Thermistor: PL Series

## For Switching Application



### ■ Characteristics

Part No.	Curie Temperature	Nominal Zero-power Resistance	Withstanding Voltage	Maximum Current	Dimensions			
	T <sub>c</sub> (°C)	R <sub>25</sub> (Ω)	V <sub>W</sub> (V <sub>AC</sub> )	I <sub>max</sub> (mA)	D(mm)	T(mm)	d±0.02(mm)	H <sub>max</sub> (mm)
PLA03101□**D2	(50/60/70/ 80/90/100/ 110/120) ±10	100	420	200	3.0~4.5	3.5~4.5	0.5	8.5
PLA03151□**D2		150	420					
PLA03221□**D2		220	420					
PLA03331□**E0		330	500					
PLA03471□**E0		470	500					
PLA03681□**E0		680	500					
PLA03102□**F0		1000	600					
PLA03152□**F0		1500	600					
PLA03222□**F0		2200	600					
PLA03332□**F0		3300	600					
PLA03472□**F0		4700	600					
PLA04680□**D2		(50/60/70/ 80/90/100/ 110/120) ±10	68					
PLA04101□**D2	100		420					
PLA04151□**D2	150		420					
PLA04221□**E0	220		500					
PLA04331□**E0	330		500					
PLA04471□**F0	470		600					
PLA04681□**F0	680		600					
PLA04102□**F0	1000		600					
PLA04152□**F0	1500		600					
PLA04222□**F0	2200		600					
PLA04332□**F0	3300		600					
PLA05680□**D2	(50/60/70/ 80/90/100/ 110/120) ±10		68	420	400	5.0~6.5	3.5~4.5	0.6
PLA05101□**D2		100	420					
PLA05151□**D2		150	420					
PLA05221□**E0		220	500					
PLA05331□**E0		330	500					
PLA05471□**F0		470	600					
PLA05681□**F0		680	600					
PLA05102□**F0		1000	600					
PLA05152□**F0		1500	600					
PLA05222□**F0		2200	600					
PLA05332□**F0		3300	600					
PLA06680□**D5		(50/60/70/ 80/90/100/ 110/120) ±10	68	450				
PLA06101□**E0	100		500					
PLA06151□**E0	150		500					
PLA06221□**F0	220		600					
PLA06331□**F0	330		600					
PLA06471□**F0	470		600					

# CPTC Thermistor: PL Series

## For Switching Application



Part No.	Curie Temperature	Nominal Zero-power Resistance	Withstanding Voltage	Maximum Current	Dimensions			
	T <sub>c</sub> (°C)	R <sub>25</sub> (Ω)	V <sub>W</sub> (V <sub>AC</sub> )	I <sub>max</sub> (mA)	D(mm)	T(mm)	d±0.02(mm)	H <sub>max</sub> (mm)
PLA06681□**F5	(50/60/70/ 80/90/100/ 110/120) ±10	680	650	600	5.5~7.5	3.5~4.5	0.6	11.5
PLA06102□**F5		1000	650					
PLA06152□**F5		1500	650					
PLA06222□**F5		2200	650					
PLA07680□**D5		68	450	800	6.5~8.5	3.5~4.5	0.6	12.5
PLA07101□**E0		100	500					
PLA07151□**E0		150	500					
PLA07221□**F0		220	600					
PLA07331□**F0		330	600					
PLA07471□**F0		470	600					
PLA07681□**F5		680	650					
PLA07102□**F5		1000	650					
PLA07152□**F5		1500	650					
PLA07222□**F5		2200	650					

Note1: □=Tolerance of R<sub>25</sub>

Note2: \*\*= Code of T<sub>c</sub> : P5, P6, P7, P8, P9, A0, A1 or A2.

### ■ R-T Characteristic Curve (Representative)

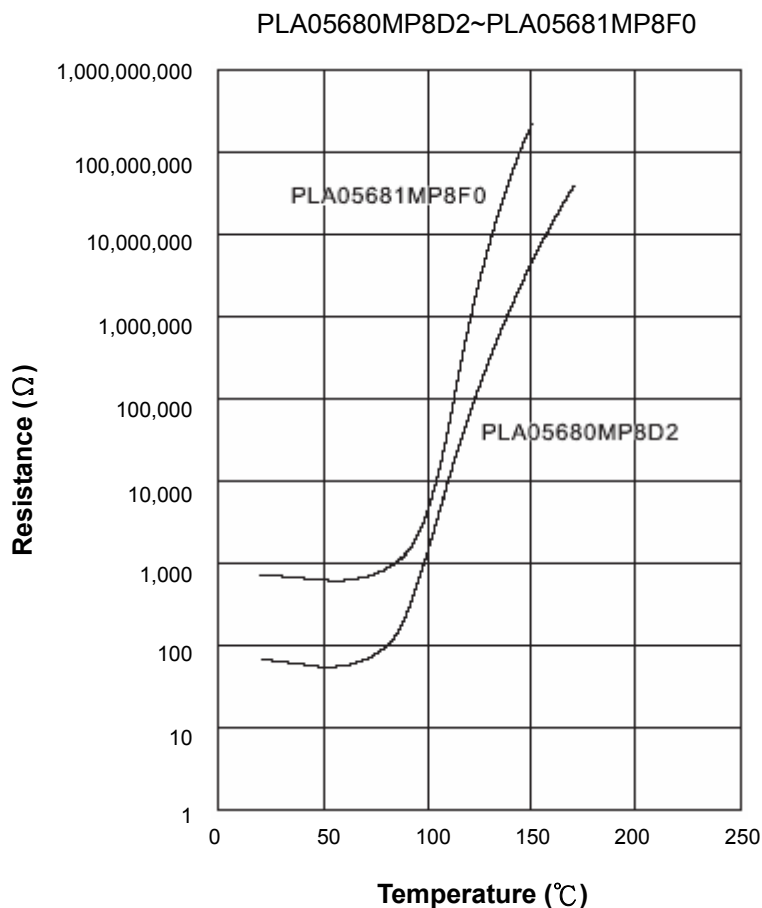

# CPTC Thermistor: PL Series

## For Switching Application



### ■ Soldering Recommendation

- Wave Flow Soldering Profile

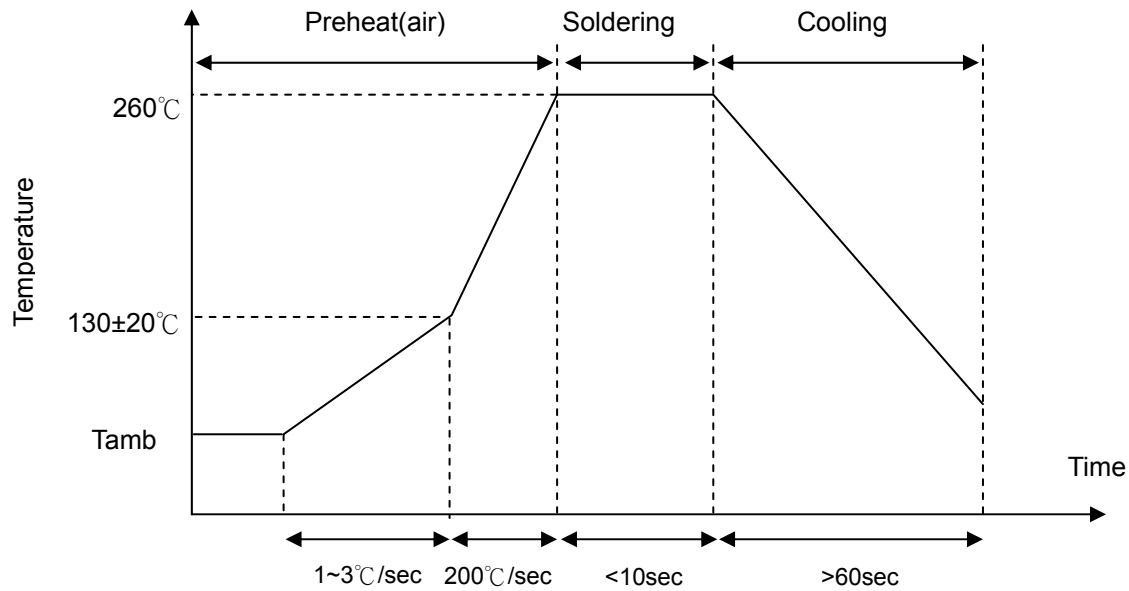

- Recommended Reworking Conditions With Soldering Iron

Item	Conditions
Temperature of Soldering Iron-tip	360°C (max.)
Soldering Time	2 sec (max.)
Distance from coating	6 mm (min.)

# CPTC Thermistor: PL Series

## For Switching Application



### ■ Reliability Test

Item	Standard	Test conditions / Methods	Specifications
Tensile Strength Of Terminals	IEC60068-2-21	Fasten body and apply a force gradually to each lead for 10±1 sec. Terminal diameter (mm)                      Force T(N) 0.35<d≤0.5                                      5.0 0.5<d≤0.8                                      10.0	ΔR/R25   ≤20% No damage observed
Solderability	IEC60068-2-20	Then dip each lead into 255±5°C solder for 3±0.5sec.to the 4±1mm above from body .	At least 95% of terminal electrode is covered by new solder
Resistance to Soldering Heat	IEC60068-2-20	Dip each lead into 350±10°C solder for 3~4sec. to the 4±1mm above body.	ΔR/R25   ≤20% No damage observed
Vibration	IEC60068-2-6	Fasten body to baseboard with solder perfectly and supply sine wave oscillation at frequency from 10 HZ to 55HZ all oscillation with 0.75 mm of Vibrato for 24 cycles in each of 3 naturally perpendicular plane for a total of 6 hours	ΔR/R25   ≤20% No damage observed
Shock	IEC60068-2-27	Putting the PTC product in the shock equipment Shock wave: half-sine ΔV=1.0m/s;Acceleration:50m/s <sup>2</sup> ;Pulse time:30ms	ΔR/R25   ≤20% No damage observed
Temp. cycle	IEC60068-2-14	-40±3°C×30min.→+85±2°C×30min    ×5Cycles excessive time:2min<T<3min	ΔR/R25   ≤20% No damage observed
Climatic sequence	IEC60738-1	+40 °C,20%R.H X 24hrs →100 °C X 16hrs→25°C X 2hrs→ +40 °C,95%R.HX 24hrs→ 0 °C X 2hrs→+40 °C,95%R.HX 24hrs→ 25 °C X (1~2)hrs	ΔR/R25   ≤20% No damage observed
Endurance at upper category temperature	IEC60068-2-2	UCT=60°C, for 1000hrs	ΔR/R25   ≤20% No damage observed
The highest temperature and max voltage load	IEC60738-1	UCT=60°C, 270V <sub>AC</sub> , I≤I <sub>max</sub> for 1000hrs	ΔR/R25   ≤20% No damage observed
Humidity	IEC60068-2-3	40±5°C,90~95%RH,For 1000±2hrs	ΔR/R25   ≤20% No damage observed
Room Temperature Intermittent Load	IEC60738-1	25±5°C, 270V <sub>AC</sub> , I≤I <sub>max</sub> 1min. on and 5min. Off ×、10,000 cycles	ΔR/R25   ≤20% No damage observed

# CPTC Thermistor: PL Series

## For Switching Application



### ■ Packaging

#### ● Taping Specification

*Lead Space 7.5mm (P0=12.7mm)*

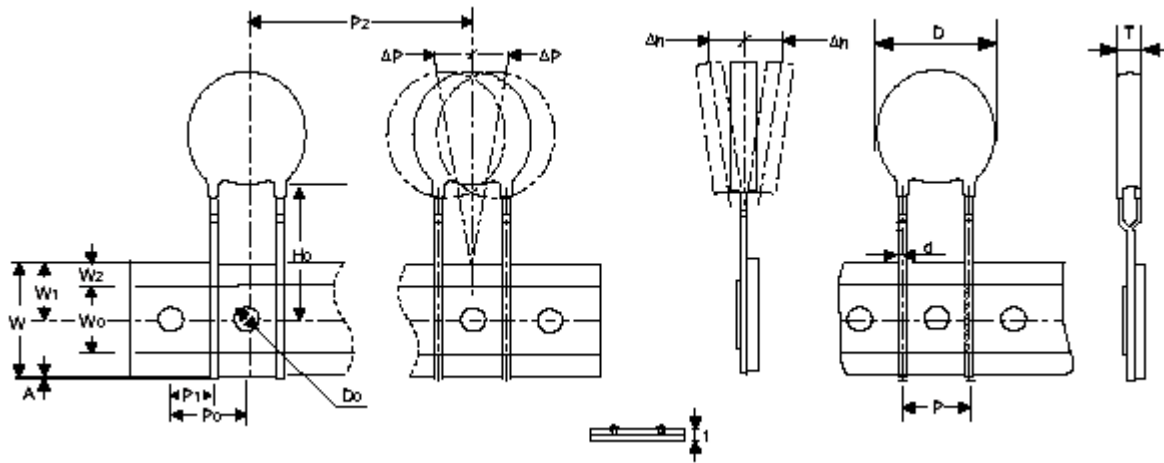

*Lead Space 2.5mm & 5.0mm & 7.5mm (P0=15mm)*

*Lead Space 2.5mm & 5.0mm (P0=12.7mm)*

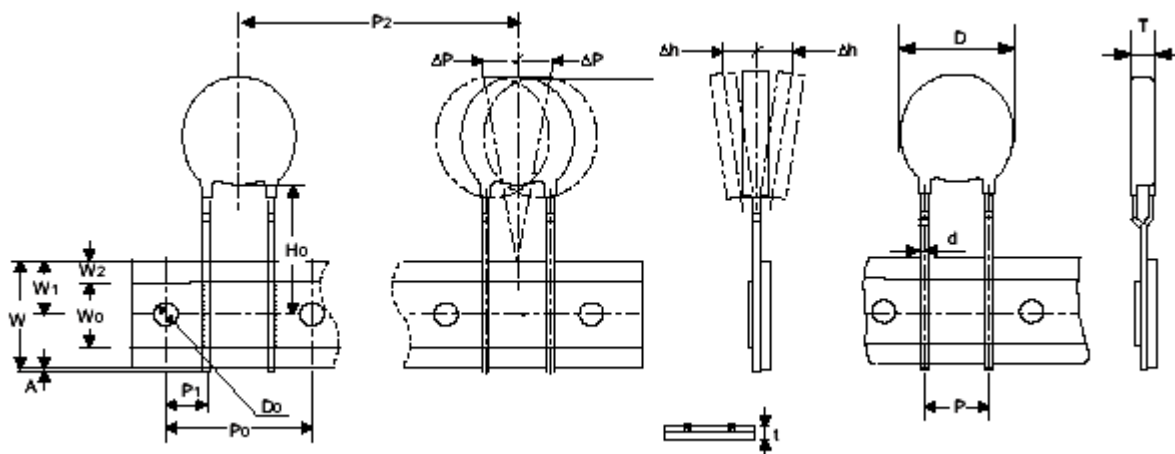

# CPTC Thermistor: PL Series

## For Switching Application



(Unit: mm)

Index	Parameter	Nominal dimensions						Tolerance
P	Lead spacing	2.5	5	7.5	2.5	5	7.5	±1
P0	Sprocket hole pitch	12.7	12.7	12.7	15	15	15	±0.3
P1	Lead location	5.1	3.85	8.95	6.25	5	3.75	±1
P2	Component pitch	12.7	12.7 (D ≤ 10)		15	15.0 (D ≤ 10)		±1
			25.4 (D > 10)			30.0 (D > 10)		
H0	Height between component and tape centre	18	18	18	18	18	18	±1
W	Carrier tape width	18	18	18	18	18	18	±1
W0	Adhesive tape width	12	12	12	12	12	12	±1
W1	Sprocket hole position	9	9	9	9	9	9	±1
W2	Adhesive tape position	3	3	3	3	3	3	±1
△P	Component alignment	1	1	1	1	1	1	Max. 1
△h	Component alignment	2	2	2	2	2	2	Max. 2
A	Tip length	0.5	0.5	0.5	0.5	0.5	0.5	Max. 0.5
D0	Sprocket hole diameter	4	4	4	4	4	4	±0.2
t	Total tape thickness	0.6	0.6	0.6	0.6	0.6	0.6	±0.2

# CPTC Thermistor: PL Series

## For Switching Application



### ■ Quantity

#### ● Bulk Packing

Disc Size/mm	Quantity (Bag/pcs)
$\Phi \leq 10$	200
$10 < \Phi < 20$	100
$\Phi \geq 20$	50

#### ● Reel Packing

1500 pcs / Reel

Disc Size	$\Phi < 16$	$\Phi \geq 16$
A	46	55

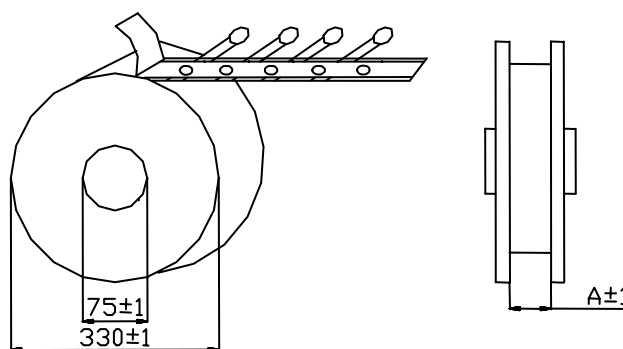

(Unit: mm)

#### ● Ammo packing

1000pcs / Ammo box

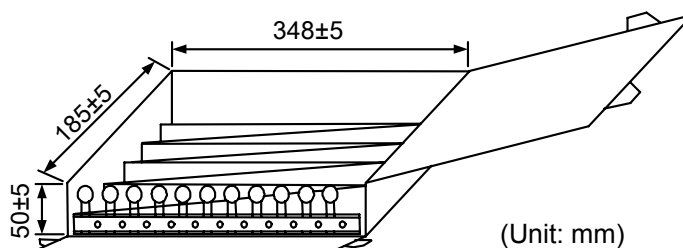

(Unit: mm)

### ■ Storage condition of products

#### ● Storage Conditions :

1. Storage Temperature :  $-10^{\circ}\text{C} \sim +40^{\circ}\text{C}$
2. Relative humidity :  $\leq 75\% \text{RH}$
3. Thermistor must be kept away from sunlight and stored in a non-corrosive atmosphere.

#### ● Period of Storage : 1 year