

Metal Oxide Varistor for Automotive : TVM-C Series



SMD Type for Transient Overvoltage Protection

■ Features

1. Qualification based on AEC-Q200 Rev-C
2. High surge suppress capability for automotive application (load dump)
3. No temperature derating up to 125 °C
4. Bidirectional and symmetrical V/I characteristics
5. Stability in high-temperature and high-humidity environment
6. RoHS & Halogen Free (HF) compliant



■ Recommended Applications

Transient overvoltage protection in automotive applications: engine management, airbag, control units, electro hydraulic brake, ABS/ESP, sunroof

■ Part Number Code

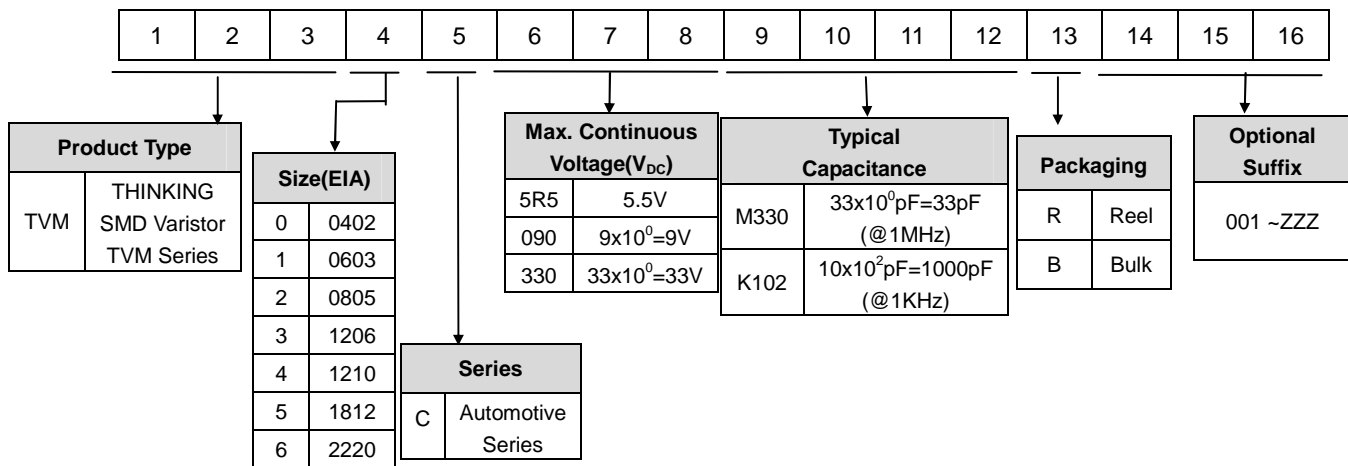

■ Structure and Dimensions

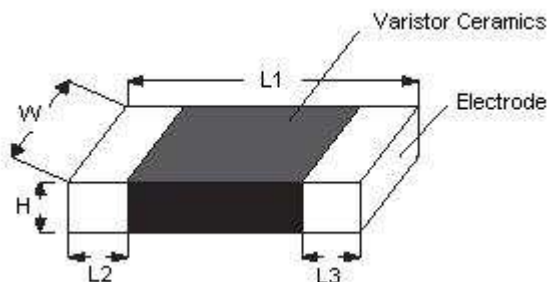

(Unit: mm)

Part No.	Size (EIA)	L1	W	H max.	L2 and L3
TVM0	0402	1.00±0.15	0.50±0.10	0.60	0.20±0.10
TVM1	0603	1.60 ±0.15	0.80±0.15	0.95	0.35±0.15
TVM2	0805	2.00 ±0.20	1.25±0.20	1.00	0.40±0.20
TVM3	1206	3.20 ±0.30	1.60±0.20	1.50	0.50±0.20
TVM4	1210	3.20 ±0.30	2.50±0.25	1.50	0.50±0.20
TVM5	1812	4.50 ±0.40	3.20±0.30	2.00	0.60±0.30
TVM6	2220	5.70±0.40	5.00±0.30	2.50	0.60±0.30

Metal Oxide Varistor for Automotive : TVM-C Series



SMD Type for Transient Overvoltage Protection

■ Electrical Characteristics

● 0402 Series

Type.	Varistor Voltage	Max. Continuous Voltage		Max. Clamping Voltage (8/20μs)		Max. Surge Current (8/20μs)	Max. Energy (10/1000μs)	Typical Capacitance		Operating Temp. Range (°C)
		V _{AC}	V _{DC}	V _P	I _P			1KHz	1MHz	
		(V)	(V)	(V)	(A)			(pF)	(pF)	
TVM0C5R5M330R	8.8~13.2	4	5.5	31	1	4	0.02	--	33±30%	-55~+125
TVM0C5R5M900R	8.8~13.2	4	5.5	30	1	10	0.05	--	90±30%	
TVM0C140K800R	16~21	11	14	35	1	10	0.05	80±30%	--	
TVM0C180M120R	22~28	14	18	55	1	2	0.03	--	12±30%	
TVM0C180M400R	22~28	14	18	50	1	20	0.05	--	40±30%	
TVM0C180M500R	22~28	14	18	50	1	20	0.05	--	50±30%	
TVM0C180M600R	22~28	14	18	50	1	20	0.05	--	60±30%	
TVM0C180M650R	22~28	14	18	50	1	20	0.05	--	65±30%	

● 0603 Series

Type.	Varistor Voltage	Max. Continuous Voltage		Max. Clamping Voltage (8/20μs)		Max. Surge Current (8/20μs)	Max. Energy (10/1000μs)	Typical Capacitance		Operating Temp. Range (°C)
		V _{AC}	V _{DC}	V _P	I _P			1KHz	1MHz	
		(V)	(V)	(V)	(A)			(pF)	(pF)	
TVM1C5R5M271R	8~12	4	5.5	25	1	20	0.1	--	270±30%	-55~+125
TVM1C090M491R	11~16	7	9	29	1	30	0.1	--	490±30%	
TVM1C180M120R	23~30	14	18	55	1	2	0.03	--	12±30%	
TVM1C180K150R	23~30	14	18	55	1	2	0.03	15±30%	--	
TVM1C180M150R	23~30	14	18	55	1	2	0.03	--	15±30%	
TVM1C220K530R	25~40	17	22	50	1	30	0.105	53±30%	--	
TVM1C220K101R	25~33	17	22	50	1	30	0.1	100±30%	--	
TVM1C260M111R	31~38	20	26	60	1	30	0.1	--	110±30%	
TVM1C310K900R	35.1~42.9	25	31	67	1	30	0.3	90±30%	--	
TVM1C320M100R	51.9~70.1	25	32	120	1	5	0.05	--	10±30%	

Metal Oxide Varistor for Automotive : TVM-C Series



SMD Type for Transient Overvoltage Protection

● 0805 Series

Type.	Varistor Voltage	Max. Continuous Voltage		Max. Clamping Voltage (8/20μs)		Max. Surge Current (8/20μs)	Max. Energy (10/1000μs)	Typical Capacitance	V _{jump} (5min)	W _{LD} (10x)	Operating Temp. Range
	V _{1mA}	V _{AC}	V _{DC}	V _P	I _P	I _{max}	W _{max}	1KHz	(V)	(J)	(°C)
	(V)	(V)	(V)	(V)	(A)	(A)	(J)	(pF)			
TVM2C160K651R	21.6~26.4	12	16	40	1	120	0.3	650±20%	24.5	1	-55~+125
TVM2C180K651R	23~28	14	18	44	1	120	0.3	650±20%	24.5	1	
TVM2C180K751R	23~28	14	18	44	1	120	0.3	750±20%	24.5	1	
TVM2C260K501R	29.7~36.3	20	26	56	1	80	0.3	500±20%	27	1	
TVM2C310K251R	35.1~42.9	25	31	67	1	80	0.3	250±20%	29	0.5	

● 1206 Series

Type.	Varistor Voltage	Max. Continuous Voltage		Max. Clamping Voltage (8/20μs)		Max. Surge Current (8/20μs)	Max. Energy (10/1000μs)	Typical Capacitance	V _{jump} (5min)	W _{LD} (10x)	Operating Temp. Range
	V _{1mA}	V _{AC}	V _{DC}	V _P	I _P	I _{max}	W _{max}	1KHz	(V)	(J)	(°C)
	(V)	(V)	(V)	(V)	(A)	(A)	(J)	(pF)			
TVM3C160K102R	21.6~26.4	12	16	40	1	200	0.6	1000±20%	24.5	1.5	-55~+125
TVM3C180K102R	22.95~28.05	14	18	42	1	150	0.6	1000±20%	24.5	1.5	
TVM3C340K551R	42.3~51.7	26	34	77	1	200	0.4	550±20%	50	1.5	
TVM3C450K301R	50.4~61.6	35	45	90	1	100	0.4	300±20%	59	1.2	
TVM3C480K271R	55.8~68.2	37	48	100	1	100	0.4	270±20%	59	1.2	
TVM3C560K251R	61.2~74.8	40	56	110	1	100	0.5	250±20%	65	1.5	

● 1210 Series

Type.	Varistor Voltage	Max. Continuous Voltage		Max. Clamping Voltage (8/20μs)		Max. Surge Current (8/20μs)	Max. Energy (10/1000μs)	Typical Capacitance	V _{jump} (5min)	W _{LD} (10x)	Operating Temp. Range
	V _{1mA}	V _{AC}	V _{DC}	V _P	I _P	I _{max}	W _{max}	1KHz	(V)	(J)	(°C)
	(V)	(V)	(V)	(V)	(A)	(A)	(J)	(pF)			
TVM4C160K242R	21.6~26.4	12	16	40	2.5	400	1.6	2400±20%	24.5	3	-55~+125
TVM4C180K312R	22.95~28.05	14	18	42	2.5	500	1.6	3100±20%	27.5	3	
TVM4C260K152R	29.7~36.3	20	26	54	2.5	400	1.9	1500±20%	27	3	
TVM4C310K122R	35.1~42.9	25	31	65	2.5	300	1.7	1200±20%	29	3	

Metal Oxide Varistor for Automotive : TVM-C Series



SMD Type for Transient Overvoltage Protection

● 1812 Series

Type.	Varistor Voltage	Max. Continuous Voltage		Max. Clamping Voltage (8/20 μ s)		Max. Surge Current (8/20 μ s)	Max. Energy (10/1000 μ s)	Typical Capacitance	V_{jump} (5min)	W_{LD} (10x)	Operating Temp. Range
	V_{1mA}	V_{AC}	V_{DC}	V_P	I_P	I_{max}	W_{max}	1KHz	(V)	(J)	(°C)
	(V)	(V)	(V)	(V)	(A)	(A)	(J)	(pF)			
TVM5C160K452R	21.6~26.4	12	16	40	5	800	2.4	4500 \pm 20%	24.5	6	-55~+125
TVM5C300K172R	35~43	23	30	77	5	600	3.8	1700 \pm 20%	45	6	

● 2220 Series

Type.	Varistor Voltage	Max. Continuous Voltage		Max. Clamping Voltage (8/20 μ s)		Max. Surge Current (8/20 μ s)	Max. Energy (10/1000 μ s)	Typical Capacitance	V_{jump} (5min)	W_{LD} (10x)	Operating Temp. Range
	V_{1mA}	V_{AC}	V_{DC}	V_P	I_P	I_{max}	W_{max}	1KHz	(V)	(J)	(°C)
	(V)	(V)	(V)	(V)	(A)	(A)	(J)	(pF)			
TVM6C160K103R	21.6~26.4	12	16	42	10	1200	5.8	10000 \pm 20%	24.5	12	-55~+125
TVM6C160K203R	21.6~26.4	12	16	42	10	1200	10	20000 \pm 20%	24.5	25	

■ Power Derating Curve

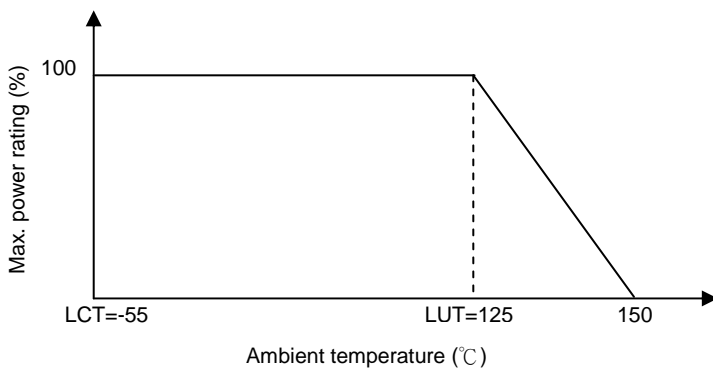

■ Surge Current Standard Waveform

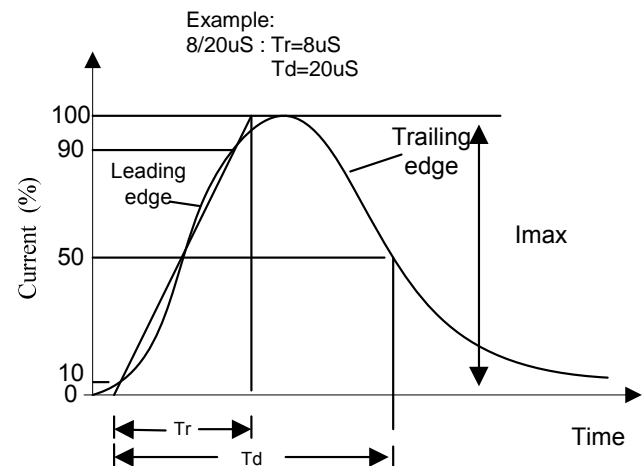

Metal Oxide Varistor for Automotive : TVM-C Series

SMD Type for Transient Overvoltage Protection



■ Soldering Recommendation

● IR-Reflow Soldering Profile

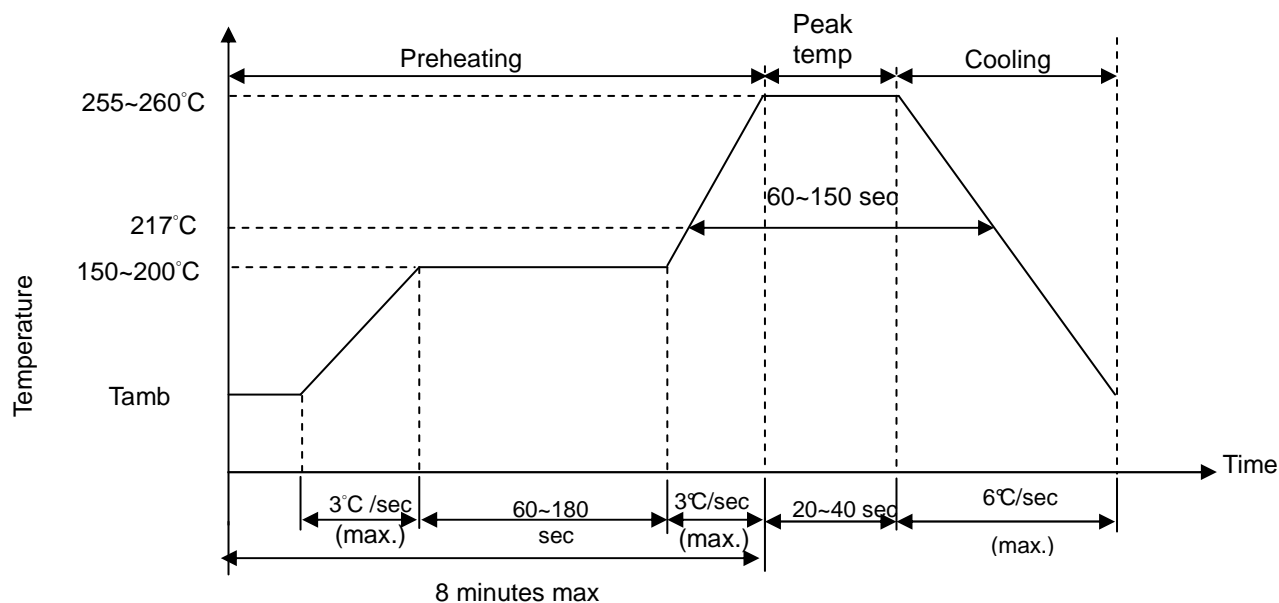

● Reworking Conditions with Soldering Iron

Item	Conditions
Temperature of Soldering Iron-tip	360°C (max.)
Soldering Time	3 sec (max.)
Diameter of Soldering Iron-tip	Φ3mm (max.)

Caution: Do not touch the component surface with soldering iron directly to prevent it from damage.

Metal Oxide Varistor for Automotive : TVM-C Series

SMD Type for Transient Overvoltage Protection



■ Recommended Soldering Pad Dimensions

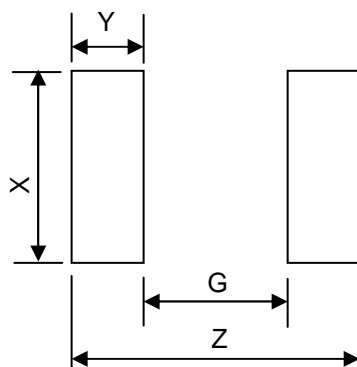

Size	Z (mm)	G (mm)	X (mm)	Y (mm)
0402	1.7	0.5	0.6	0.6
0603	3.0	1.0	1.0	1.0
0805	3.4	1.0	1.4	1.2
1206	4.5	2.1	1.8	1.2
1210	4.5	2.1	2.8	1.2
1812	6.0	3.0	3.6	1.5
2220	7.2	4.2	5.5	1.5

Metal Oxide Varistor for Automotive : TVM-C Series

SMD Type for Transient Overvoltage Protection



■ Reliability (based on AEC-Q200 Rev-C)

Item	Standard	Test conditions / Methods	Specifications																																										
High Temperature Exposure (Storage)	MIL-STD-202 Method 108	Test temp. : 150 +3/-0°C Duration: 1000 h Unpowered Measurement at 24±2 hours after test conclusion.	No visible damage $ \Delta V_{1mA}/V_{1mA} \leq 10\%$																																										
Temperature Cycling	JESD22 Method JA-104	Lower test temp. : -40 +0/-3°C Upper test temp. : 125 +3/-0°C Soak time at lower or upper temp. : 1 min Cycle time: 2 Cycles/hr Number of cycles: 1000 Measurement at 24±2 hours after test conclusion.	No visible damage $ \Delta V_{1mA}/V_{1mA} \leq 10\%$																																										
Moisture Resistance	MIL-STD-202 Method 106	Duration of 1 cycle: 24 h Number of cycles: 10, Unpowered Measurement at 24±2 hours after test conclusion. <table border="1" style="margin: 10px auto;"> <thead> <tr> <th rowspan="2">Step</th> <th colspan="2">Temp. (°C)</th> <th rowspan="2">Humidity (%)</th> <th rowspan="2">Period (hr)</th> </tr> <tr> <th>Start</th> <th>Finish</th> </tr> </thead> <tbody> <tr> <td>1</td> <td>25</td> <td>65</td> <td>90~100</td> <td>2.5</td> </tr> <tr> <td>2</td> <td>65</td> <td>65</td> <td>90~100</td> <td>3</td> </tr> <tr> <td>3</td> <td>65</td> <td>25</td> <td>80~100</td> <td>2.5</td> </tr> <tr> <td>4</td> <td>25</td> <td>65</td> <td>90~100</td> <td>2.5</td> </tr> <tr> <td>5</td> <td>65</td> <td>65</td> <td>90~100</td> <td>3</td> </tr> <tr> <td>6</td> <td>65</td> <td>25</td> <td>80~100</td> <td>2.5</td> </tr> <tr> <td>7</td> <td>25</td> <td>25</td> <td>80~100</td> <td>8</td> </tr> </tbody> </table>	Step	Temp. (°C)		Humidity (%)	Period (hr)	Start	Finish	1	25	65	90~100	2.5	2	65	65	90~100	3	3	65	25	80~100	2.5	4	25	65	90~100	2.5	5	65	65	90~100	3	6	65	25	80~100	2.5	7	25	25	80~100	8	No visible damage $ \Delta V_{1mA}/V_{1mA} \leq 10\%$
Step	Temp. (°C)			Humidity (%)	Period (hr)																																								
	Start	Finish																																											
1	25	65	90~100	2.5																																									
2	65	65	90~100	3																																									
3	65	25	80~100	2.5																																									
4	25	65	90~100	2.5																																									
5	65	65	90~100	3																																									
6	65	25	80~100	2.5																																									
7	25	25	80~100	8																																									
Biased Humidity	MIL-STD-202 Method 103	Test temp. : 85°C Rel. humidity of air: 85% Duration: 1000 h Bias at Working Voltage Vdc. Measurement at 24±2 hours after test conclusion.	No visible damage $ \Delta V_{1mA}/V_{1mA} \leq 10\%$																																										

Metal Oxide Varistor for Automotive : TVM-C Series

SMD Type for Transient Overvoltage Protection



Item	Standard	Test conditions / Methods	Specifications
Operational Life	MIL-STD-202 Method 108	Test temp.: 125 +3/-0°C Duration: 1000 h Bias at Working Voltage Vdc. Measurement at 24±2 hours after test conclusion.	No visible damage $ \Delta V_{1mA}/V_{1mA} \leq 10\%$
External Visual	MIL-STD-883 Method 2009	Inspect device construction, marking and workmanship.	No visible damage
Physical Dimension	JESD22 Method JB-100	Verify physical dimensions to the applicable device specification.	Within the specified values
Resistance to Solvents	MIL-STD-202 Method 215	Per MIL-STD-202 Method 215 Solvent 1: 1 part (by volume) of isopropyl alcohol 3 part (by volume) of mineral spirits.	No visible damage
Mechanical Shock	MIL-STD -202-213	Test Condition F Peak value: 1500g's Half sine Waveform Normal duration (D) : 0.5ms In 3 directions perpendicularly intersecting each other (total 18 times).	No visible damage $ \Delta V_{1mA}/V_{1mA} \leq 10\%$
Vibration	MIL-STD-202 Method 204	Acceleration: 5 g's Sweep time: 20 min Frequency range: 10 to 2000 Hz 3×12 cycles	No visible damage $ \Delta V_{1mA}/V_{1mA} \leq 10\%$
Resistance to Soldering Heat	MIL-STD-202 Method 210	Condition B No pre-heat of samples. Temperature : 260±5°C, Time : 10±1s Immersion and emersion rate : 25mm/s ±6 mm/s Number of heat cycles : 1	No visible damage $ \Delta V_{1mA}/V_{1mA} \leq 5\%$
Thermal Shock	MIL-STD-202 Method 107	Lower test temp. : -55 +0/-3°C Upper test temp. : 125 +3/-0°C Maximum transfer time: 20 seconds. Dwell time: 15 minutes. Air-Air. Number of cycles: 300	No visible damage $ \Delta V_{1mA}/V_{1mA} \leq 10\%$

Metal Oxide Varistor for Automotive : TVM-C Series

SMD Type for Transient Overvoltage Protection



Item	Standard	Test conditions / Methods	Specifications
ESD	AEC-Q200 -002	Discharge capacitance: 150 pF Charging voltage: 6 KV Contact discharge 1 pulse in each polarity	No visible damage $ \Delta V_{1mA}/V_{1mA} \leq 10\%$
Solderability	IEC 60068-2- 58 J-STD-002	a) 4 h @ 155°C dry heat Dip @ 245±5°C 3±0.3sec b) Steam aging 8h±15min @ 93±3°C Dip @ 260±5°C 7±0.5sec	95% of termination wetted
Electrical Characterization	Specifications	V1mA(-55°C) · V1mA(25°C) · V1mA(125°C)	Within the specified values
Board Flex	AEC-Q200 -005 (JIS-C-6429)	Bend the board: 2mm (Min.) Duration: 60 (+5) Sec	No visible damage $ \Delta V_{1mA}/V_{1mA} \leq 10\%$
Terminal Strength	AEC-Q200 -006 (JIS-C-6429)	Apply force: 0402=0.5kg (5 N) 0603=1.0kg (10 N) Chip size>0805=1.8kg (17.7 N) Duration of the applied forces : 60 (+1) Sec	No visible damage $ \Delta V_{1mA}/V_{1mA} \leq 10\%$
Electrical Transient Conduction	(ISO-7637-2)	Test pulses 5a Number of pulses: 10 Test Energy : W_{LD} (Load dump)	No visible damage $ \Delta V_{1mA}/V_{1mA} \leq 15\%$

SMD Type for Transient Overvoltage Protection

■ Packaging

● Taping Specification (SMD 0402)

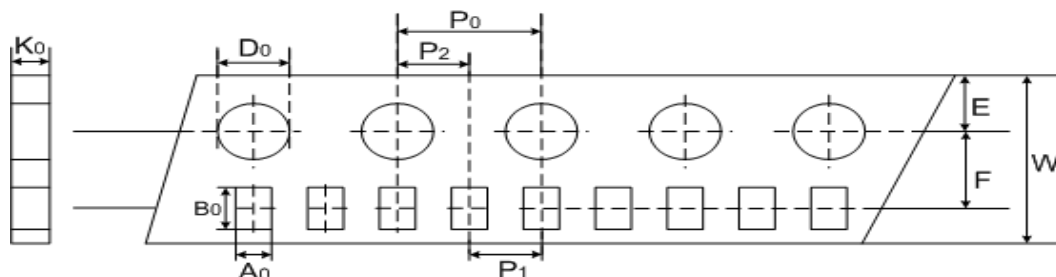

(Unit: mm)

Index	A_0	B_0	W	E	F	P_1	P_2	P_0	D_0	K_0
Size	± 0.05	± 0.12	± 0.2	± 0.1	± 0.05	± 0.1	± 0.05	± 0.1	± 0.1	± 0.1
0402	0.62	1.12	8	1.75	3.5	2	2	4	1.55	0.60

● Taping Specification (SMD 0603 & 0805)

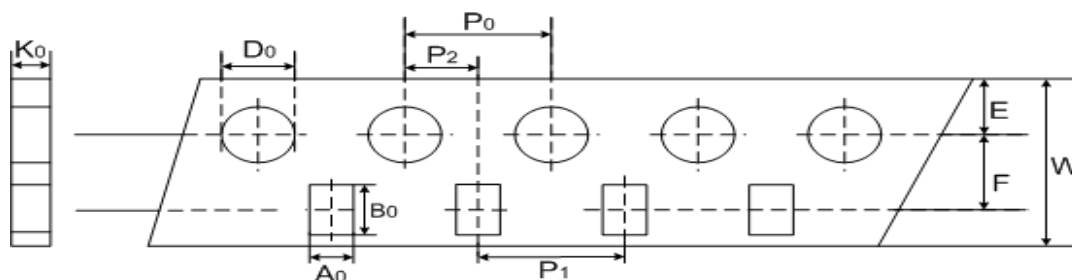

(Unit: mm)

Index	A_0	B_0	W	E	F	P_1	P_2	P_0	D_0	K_0
Size	± 0.2	± 0.2	± 0.2	± 0.1	± 0.05	± 0.1	± 0.05	± 0.1	± 0.1	± 0.1
0603	1.1	1.9	8	1.75	3.5	4	2	4	1.55	0.95
0805	1.5	2.3	8	1.75	3.5	4	2	4	1.55	1.0

SMD Type for Transient Overvoltage Protection

● Taping Specification(SMD 1206 & 1210)

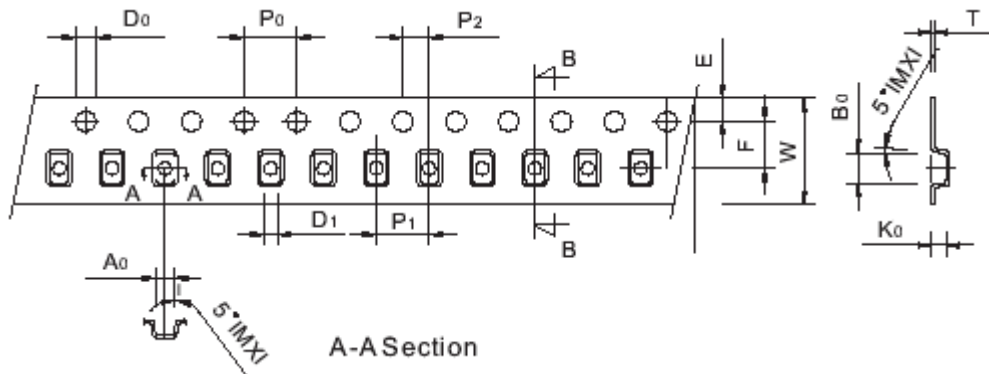

(Unit: mm)

Index Size	A_0	B_0	W	E	F	P_1	P_2	P_0	D_0	D_1	T
1206	± 0.2	± 0.2	± 0.2	± 0.1	± 0.05	± 0.1	± 0.05	± 0.1	± 0.1	± 0.1	± 0.1
1210	2.75	3.55	8	1.75	3.5	4	2	4	1.55	1	0.25

● Taping Specification(SMD 1812 & 2220)

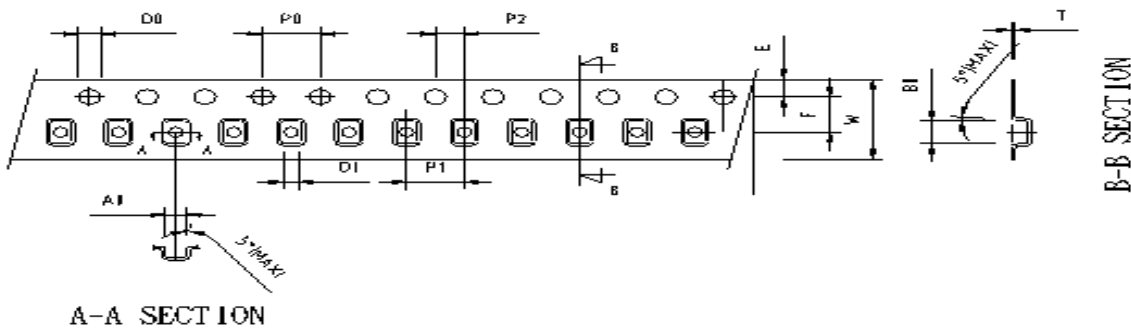

(Unit: mm)

Index Size	A_0	B_0	W	E	F	P_1	P_2	P_0	D_0	D_1	T
1812	± 0.2	± 0.2	± 0.3	± 0.1	± 0.05	± 0.1	± 0.05	± 0.1	± 0.1	± 0.1	± 0.1
2220	5.50	6.25	12	1.75	5.5	8	2	4	1.55	1.5	0.25

Metal Oxide Varistor for Automotive : TVM-C Series

SMD Type for Transient Overvoltage Protection



- Quantity

- ◆ 0402 ~ 1210

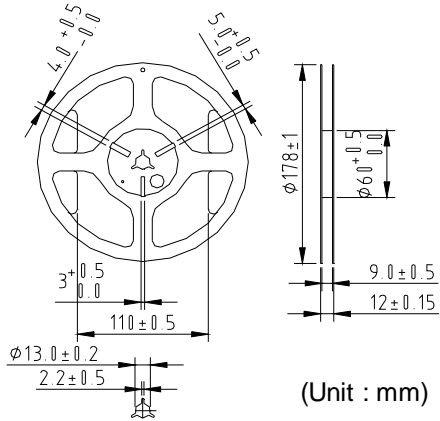

Type	Quantity (pcs/reel)
0402	10,000
0603	4,000
0805	3,500
1206	2,500
1210	2,500

- ◆ 1812~2220

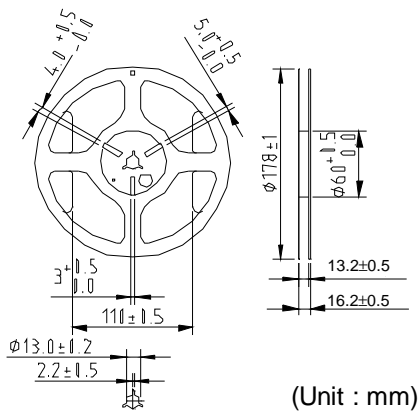

Type	Quantity (pcs/reel)
1812	1,000
2220	850

- Warehouse Storage Conditions of Products

- Storage Conditions :

1. Storage Temperature: -10°C ~ +40°C
2. Relative Humidity: ≤ 75%RH
3. Keep away from corrosive atmosphere and sunlight.

- Period of Storage : 1 year