

# Metal Oxide Varistor : TVR-V Series



## Multi-Surge Series

### ■ Features

1. Body size:  $\Phi 10$  and  $\Phi 14$  mm
2. Multi-surge capacity of combination wave 6KV/3KA.
3. Wide operating voltage range: 130Vac ~ 680Vac
4. Operating temperature range:  $-40^{\circ}\text{C}$  ~  $+85^{\circ}\text{C}$
5. Agency recognition: UL 1449 3<sup>rd</sup> /cUL/VDE
6. RoHS compliant & Halogen-free series available

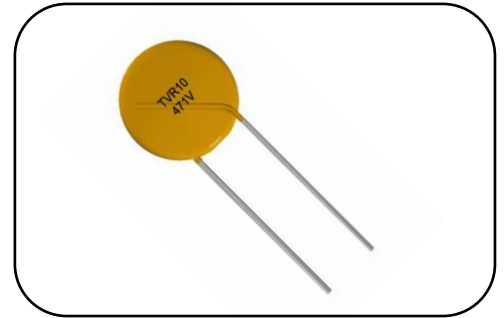

### ■ Recommended Applications

1. Power supply
2. Home appliance
3. Industrial equipment
4. Telecommunication or telephone system
5. PLC (power line commutation)

### ■ Part Number Code

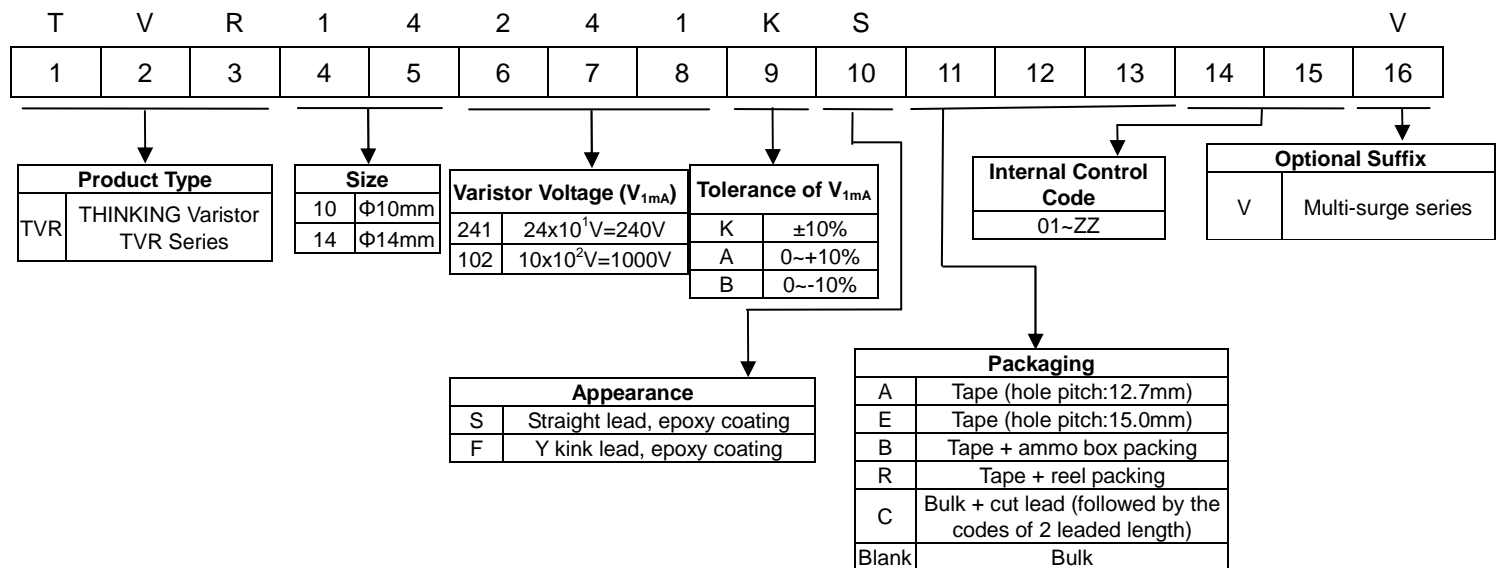

Note: Optional suffix will be the 11<sup>th</sup> digit if packaging and internal control codes are not coded.

# Metal Oxide Varistor : TVR-V Series

## Multi-Surge Series



### ■ Structure and Dimensions

- S Type (Straight lead)

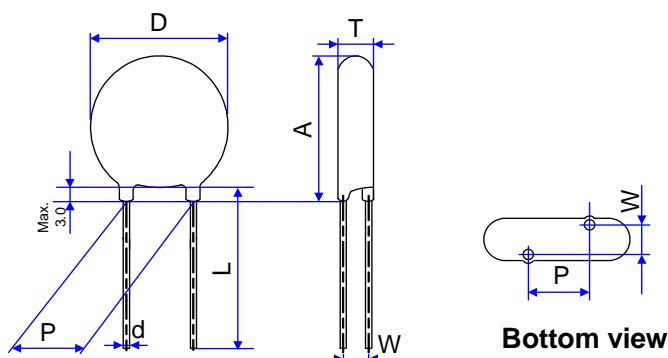

(Unit: mm)

Disc Size	D max.	L min.	d	P.	A max.	T max.	W
10-V	9.5~12.5	26.5	$0.8 \pm 0.02$	$7.5 \pm 1$	15.0	Please refer to Electrical Characteristics Table	
14-V	13.5~16.0	26.5	$0.8 \pm 0.02$	$7.5 \pm 1$	18.5 (for TVR14201-511) 19.0 (for TVR14561-112)		

- F Type (Y kink lead)

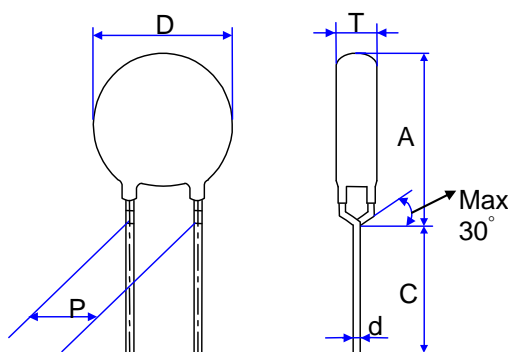

(Unit: mm)

Disc Size	D max.	C min.	d	P.	A max.	T max.
10-V	9.5~12.5	25	$0.8 \pm 0.02$	$7.5 \pm 1$	16.0	Please refer to Electrical Characteristics Table
14-V	13.5 ~16.0	25	$0.8 \pm 0.02$	$7.5 \pm 1$	19.0	

- J Type (L kink lead)

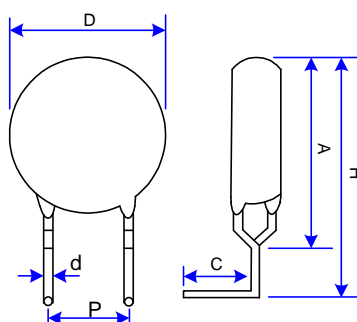

(Unit:mm)

Disc Size	D max.	C	d	P	Amax.	H max.	T max.
10-V	12.0	$4.0 \pm 1$	$0.8 \pm 0.02$	$7.5 \pm 1$	16.0	20.0	Please refer to Electrical Characteristics Table
14-V	16.0				19.5	23.5	

# Metal Oxide Varistor : TVR-V Series

## Multi-Surge Series



### ■ Electrical Characteristics

Part No.	Varistor Voltage (@ 1mA DC)	Max. Operating Voltage		Max. Clamping Voltage (8/20μs)		Max. Surge Current (8/20μs)	Surge Capacity	Rated Power	Max. Energy (10/1000μs)	Reference Capacitance @1KHz	Dimension			UL1449 3 <sup>rd</sup>
	V <sub>1mA</sub>	V <sub>AC(rms)</sub>	V <sub>DC</sub>	I <sub>p</sub>	V <sub>P</sub>	I <sub>max</sub>	@6KV/ 3KA	W	E	C <sub>p</sub>	T <sub>min</sub>	T <sub>max</sub>	W ±1.0	SPD TYPE
	(V)	(V)	(V)	(A)	(V)	(A)	Times	(W)	(J)	(PF)	(mm)			
TVR10201KSV	200 (180~220)	130	170	25	340	3500	25	0.4	35	570	2.9	4.4	1.7	3
TVR10221KSV	220 (198~242)	140	180	25	360	3500	25	0.4	39	520	3.0	4.5	1.7	3
TVR10241KSV	240 (216~264)	150	200	25	395	3500	25	0.4	42	480	3.1	4.6	1.8	3
TVR10271KSV	270 (243~297)	175	225	25	455	3500	25	0.4	49	425	3.3	5.0	1.9	3
TVR10301KSV	300 (270~330)	195	250	25	500	3500	25	0.4	53	380	3.5	5.3	2.1	3
TVR10331KSV	330 (297~363)	215	275	25	550	3500	25	0.4	58	350	3.8	5.7	2.2	3
TVR10361KSV	360 (324~396)	230	300	25	595	3500	25	0.4	65	320	4.0	6.0	2.3	3
TVR10391KSV	390 (351~429)	250	320	25	650	3500	25	0.4	70	295	4.2	6.2	2.5	3
TVR10431KSV	430 (387~473)	275	350	25	710	3500	25	0.4	80	260	4.3	6.5	2.5	3
TVR10471KSV	470 (423~517)	300	385	25	775	3500	25	0.4	85	240	4.4	6.6	2.6	3
TVR10511KSV	510 (459~561)	320	410	25	845	3500	25	0.4	92	220	4.6	6.8	2.8	3
TVR10561KSV	560 (504~616)	350	450	25	930	3500	25	0.4	92	200	4.7	7.1	3.0	3
TVR10621KSV	620 (558~682)	395	510	25	1020	3500	25	0.4	95	180	4.8	7.2	3.2	3
TVR10681KSV	680 (612~748)	420	560	25	1120	3500	25	0.4	98	175	4.9	7.4	3.4	3
TVR10751KSV	750 (675~825)	465	615	25	1235	3500	25	0.4	100	160	5.1	7.6	3.7	3
TVR10821KSV	820 (738~902)	510	670	25	1355	3500	25	0.4	110	150	5.2	7.8	3.4	3
TVR10911KSV	910 (819~1001)	550	745	25	1500	3500	25	0.4	130	130	5.3	8.0	3.7	3
TVR10102KSV	1000 (900~1100)	625	825	25	1650	3500	25	0.4	140	120	5.3	8.3	4.0	3
TVR10112KSV	1100 (990~1210)	680	895	25	1815	3500	25	0.4	155	110	5.7	8.6	4.3	3

# Metal Oxide Varistor : TVR-V Series

## Multi-Surge Series



### ■ Electrical Characteristics

Part No.	Varistor Voltage (@ 1mA DC)	Max. Operating Voltage		Max. Clamping Voltage (8/20µs)		Max. Surge Current (8/20µs)	Nominal Discharge Current (*1)	Surge capacity	Rated Power	Max. Energy (10/1000µs)	Reference Capacitance @1KHz	Dimension			UL1449 3 <sup>rd</sup> SPD TYPE (*2)
	V <sub>1mA</sub>	V <sub>AC(rms)</sub>	V <sub>DC</sub>	I <sub>p</sub>	V <sub>P</sub>	I <sub>max</sub>	I <sub>n</sub>	@6KV/ 3KA	W	E	C <sub>p</sub>	T <sub>min</sub>	T <sub>max</sub>	W ±1.0	
	(V)	(V)	(V)	(A)	(V)	(A)	(A)	Times	(W)	(J)	(PF)	(mm)			
TVR14201KSV	200 (180~220)	130	170	50	340	6000	3000	60	0.6	84	970	2.9	4.4	1.7	5
TVR14221KSV	220 (198~242)	140	180	50	360	6000	3000	60	0.6	91	880	3.0	4.5	1.7	5
TVR14241KSV	240 (216~264)	150	200	50	395	6000	3000	60	0.6	98	820	3.1	4.7	1.8	5
TVR14271KSV	270 (243~297)	175	225	50	455	6000	3000	60	0.6	112	720	3.3	4.9	1.9	5
TVR14301KSV	300 (270~330)	195	250	50	500	6000	3000	60	0.6	123	650	3.4	5.1	2.1	5
TVR14331KSV	330 (297~363)	215	275	50	550	6000	3000	60	0.6	133	600	3.5	5.3	2.2	5
TVR14361KSV	360 (324~396)	230	300	50	595	6000	3000	60	0.6	147	550	3.6	5.5	2.3	5
TVR14391KSV	390 (351~429)	250	320	50	650	6000	3000	60	0.6	161	500	3.7	5.6	2.5	5
TVR14431KSV	430 (387~473)	275	350	50	710	6000	3000	60	0.6	182	440	3.8	5.7	2.5	5
TVR14471KSV	470 (423~517)	300	385	50	775	6000	3000	60	0.6	196	400	3.9	5.9	2.6	5
TVR14511KSV	510 (459~561)	320	420	50	845	6000	3000	60	0.6	210	370	4.1	6.1	2.8	5
TVR14561KSV	560 (504~616)	350	460	50	930	6000	3000	60	0.6	231	340	4.2	6.4	3.0	5
TVR14621KSV	620 (558~682)	395	510	50	1020	6000	3000	60	0.6	252	300	4.5	6.7	3.2	5
TVR14681KSV	680 (612~748)	420	560	50	1120	6000	3000	60	0.6	266	290	4.7	7.1	3.4	5
TVR14751KSV	750 (675~825)	465	615	50	1235	6000	3000	60	0.6	280	270	5.0	7.5	3.7	5
TVR14821KSV	820 (738~902)	510	670	50	1355	6000	3000	60	0.6	280	250	5.2	7.9	3.4	5
TVR14911KSV	910 (819~1001)	550	745	50	1500	6000	3000	60	0.6	308	220	5.6	8.4	3.7	5
TVR14102KSV	1000 (900~1100)	625	825	50	1650	6000	3000	60	0.6	336	200	5.9	8.9	4.0	5
TVR14112KSV	1100 (990~1210)	680	895	50	1815	6000	3000	60	0.6	364	180	6.3	9.5	4.3	5

\*1. Per UL 1449 3rd, "Nominal Discharge Current" is the peak value of the surge current applied to varistor, having the waveshape of 8/20 µs. Varistor is expected to remain functional after 15 surges.





\*2. SPD Type 5 also can be applied for SPD Type 2 application based on selecting suitable "Nominal Discharge Current" rating.

# Metal Oxide Varistor : TVR-V Series

## Multi-Surge Series





### ■ Safety Approvals

Part No.	Certified Model No.	Agency			
					
		UL1449 3 <sup>rd</sup> &cUL : E314979	5944	IEC60950-1 2 <sup>nd</sup> Annex Q	CQC10001041748 CQC10001041749
TVR10201KSV	TVR10201-V	√	√	√	√
TVR10221KSV	TVR10221-V	√	√	√	√
TVR10241KSV	TVR10241-V	√	√	√	√
TVR10271KSV	TVR10271-V	√	√	√	√
TVR10301KSV	TVR10301-V	√	√	√	√
TVR10331KSV	TVR10331-V	√	√	√	√
TVR10361KSV	TVR10361-V	√	√	√	√
TVR10391KSV	TVR10391-V	√	√	√	√
TVR10431KSV	TVR10431-V	√	√	√	√
TVR10471KSV	TVR10471-V	√	√	√	√
TVR10511KSV	TVR10511-V	√	√	√	√
TVR10561KSV	TVR10561-V	√	√	√	√
TVR10621KSV	TVR10621-V	√	√	√	√
TVR10681KSV	TVR10681-V	√	√	√	√
TVR10751KSV	TVR10751-V	√	√	√	√
TVR10821KSV	TVR10821-V	√	√	√	√
TVR10911KSV	TVR10911-V	√	√	√	√
TVR10102KSV	TVR10102-V	√	√	√	√
TVR10112KSV	TVR10112-V	√	√	√	√

# Metal Oxide Varistor : TVR-V Series

## Multi-Surge Series



Part No.	Certified Model No.	Agency		
				
		UL1449 3 <sup>rd</sup> &cUL : E314979	5944	IEC60950-1 2 <sup>nd</sup> Annex Q
TVR14201KSV	TVR14201-V	√	√	√
TVR14221KSV	TVR14221-V	√	√	√
TVR14241KSV	TVR14241-V	√	√	√
TVR14271KSV	TVR14271-V	√	√	√
TVR14301KSV	TVR14301-V	√	√	√
TVR14331KSV	TVR14331-V	√	√	√
TVR14361KSV	TVR14361-V	√	√	√
TVR14391KSV	TVR14391-V	√	√	√
TVR14431KSV	TVR14431-V	√	√	√
TVR14471KSV	TVR14471-V	√	√	√
TVR14511KSV	TVR14511-V	√	√	√
TVR14561KSV	TVR14561-V	√	√	√
TVR14621KSV	TVR14621-V	√	√	√
TVR14681KSV	TVR14681-V	√	√	√
TVR14751KSV	TVR14751-V	√	√	√
TVR14821KSV	TVR14821-V	√	√	√
TVR14911KSV	TVR14911-V	√	√	√
TVR14102KSV	TVR14102-V	√	√	√
TVR14112KSV	TVR14112-V	√	√	√

# Metal Oxide Varistor : TVR-V Series



## Multi-Surge Series

### ■ Power Derating Curve

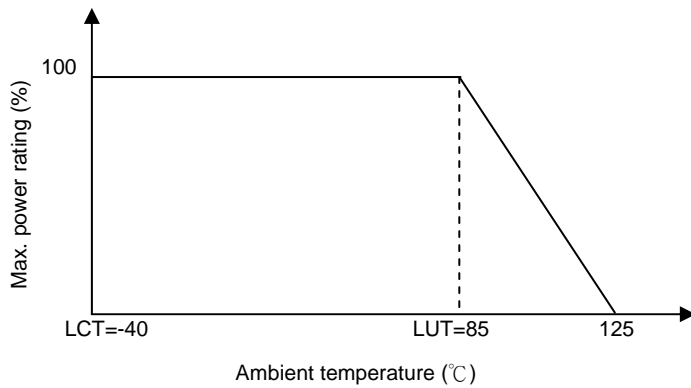

### ■ Surge Current Standard Waveform

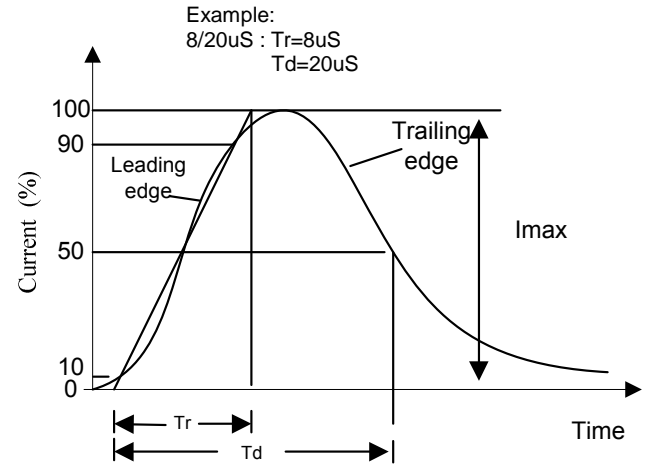

### ■ Max. Surge Current Derating Curves

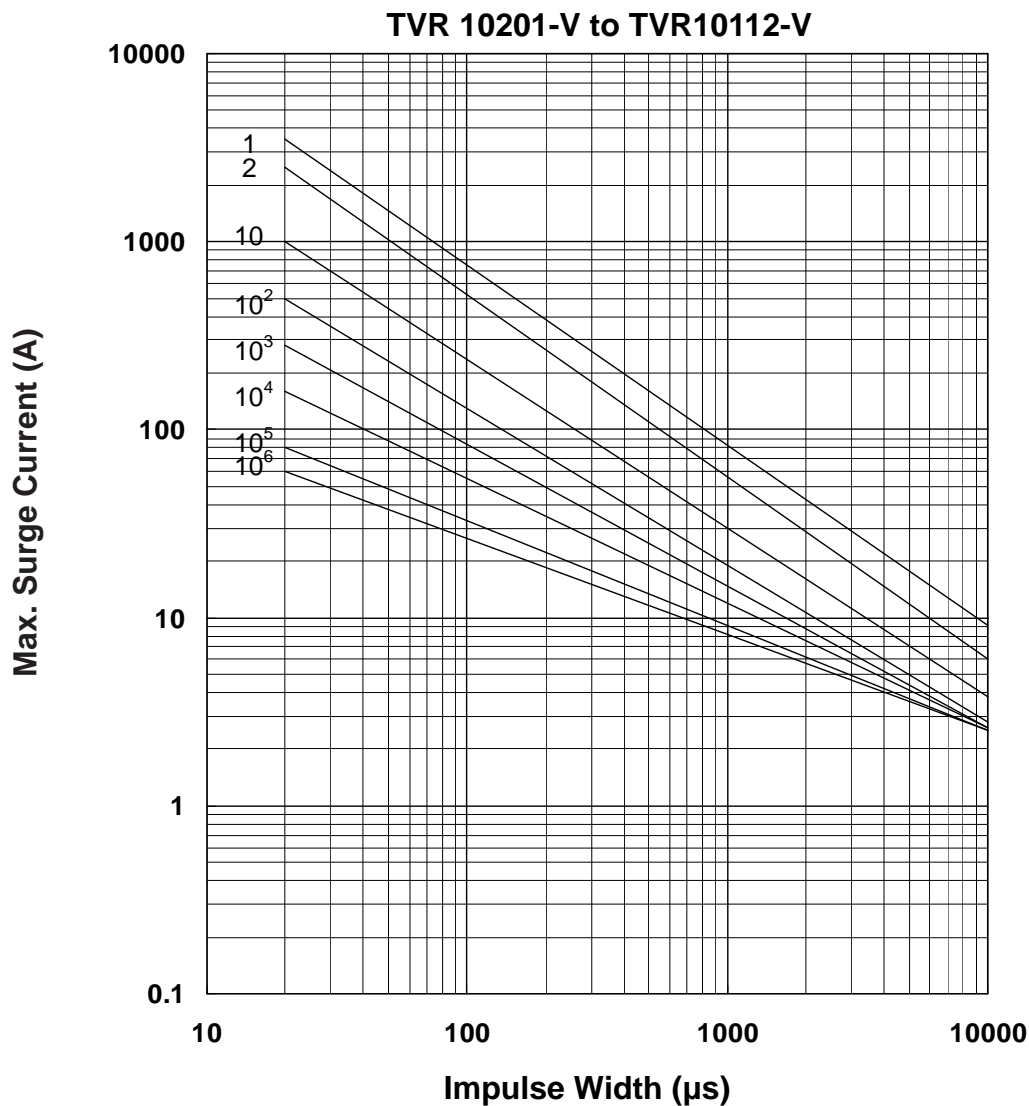

# Metal Oxide Varistor : TVR-V Series

## Multi-Surge Series



TVR 14201-V to TVR14112-V

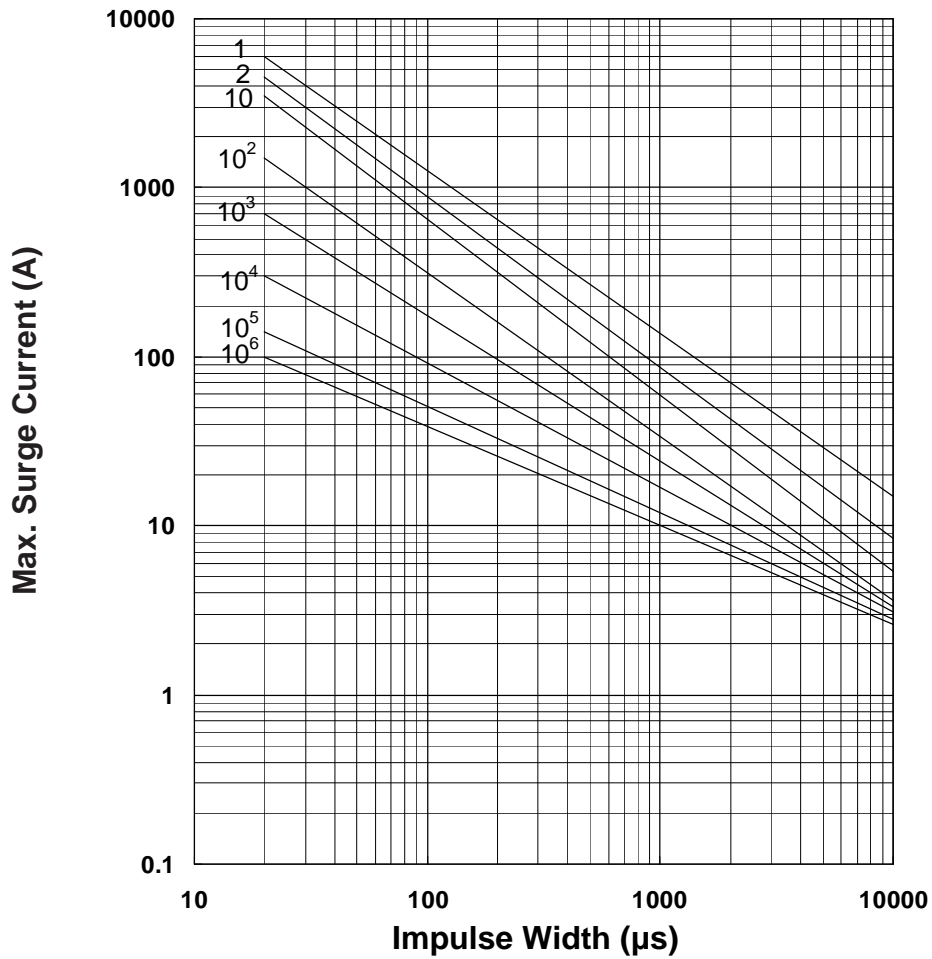

### ■ Max. Leakage Current and Max. Clamping Voltage Curves

Max. Leakage Current and Max. Clamping Voltage Curves (TVR 10 201-V to TVR 10621-V)

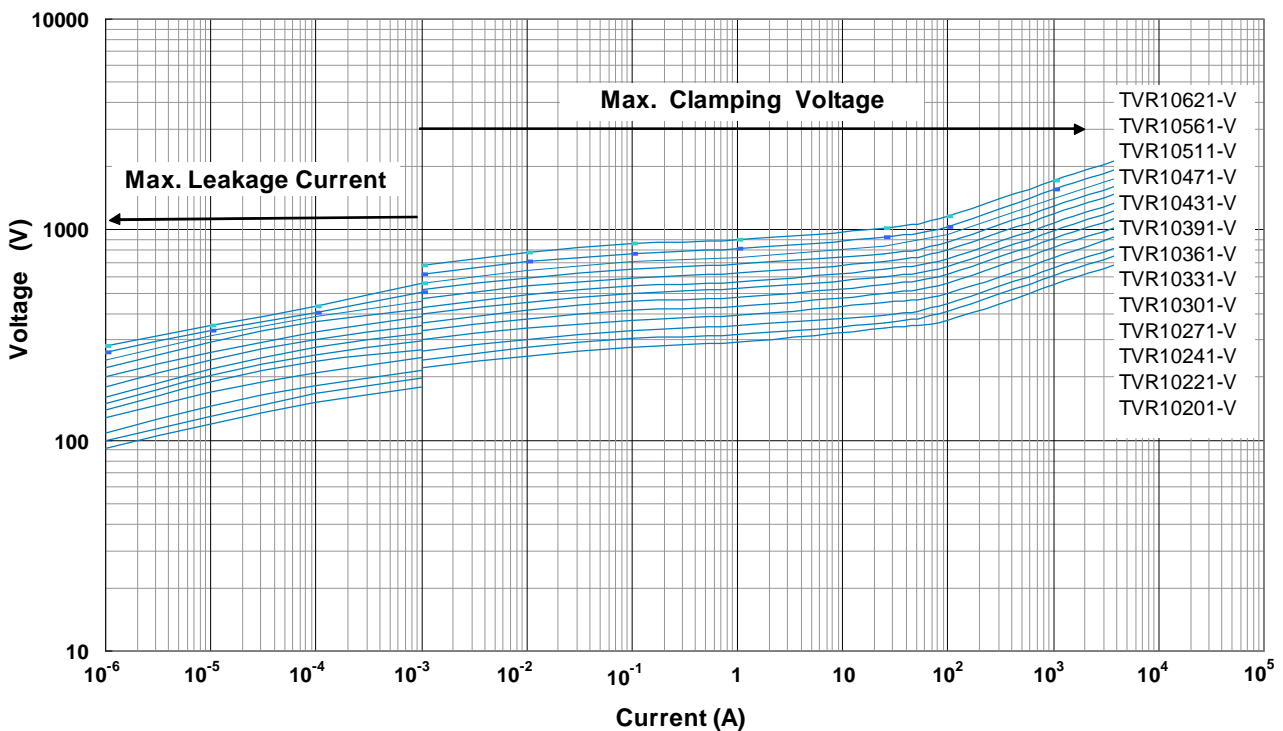

# Metal Oxide Varistor : TVR-V Series

## Multi-Surge Series



**Max. Leakage Current and Max. Clamping Voltage Curves (TVR 10 681-V to TVR 10 112-V)**

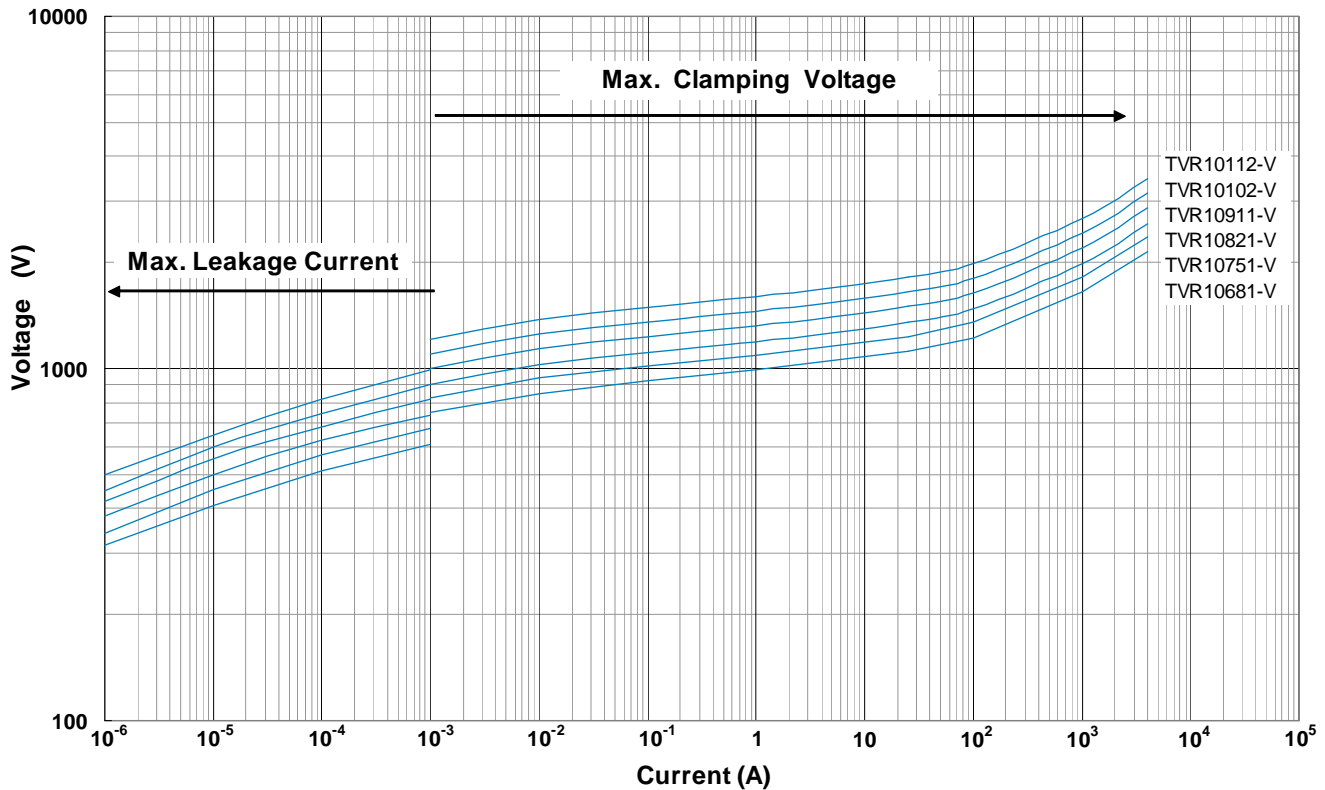

**Max. Leakage Current and Max. Clamping Voltage Curves (TVR14201-V to TVR14471-V)**

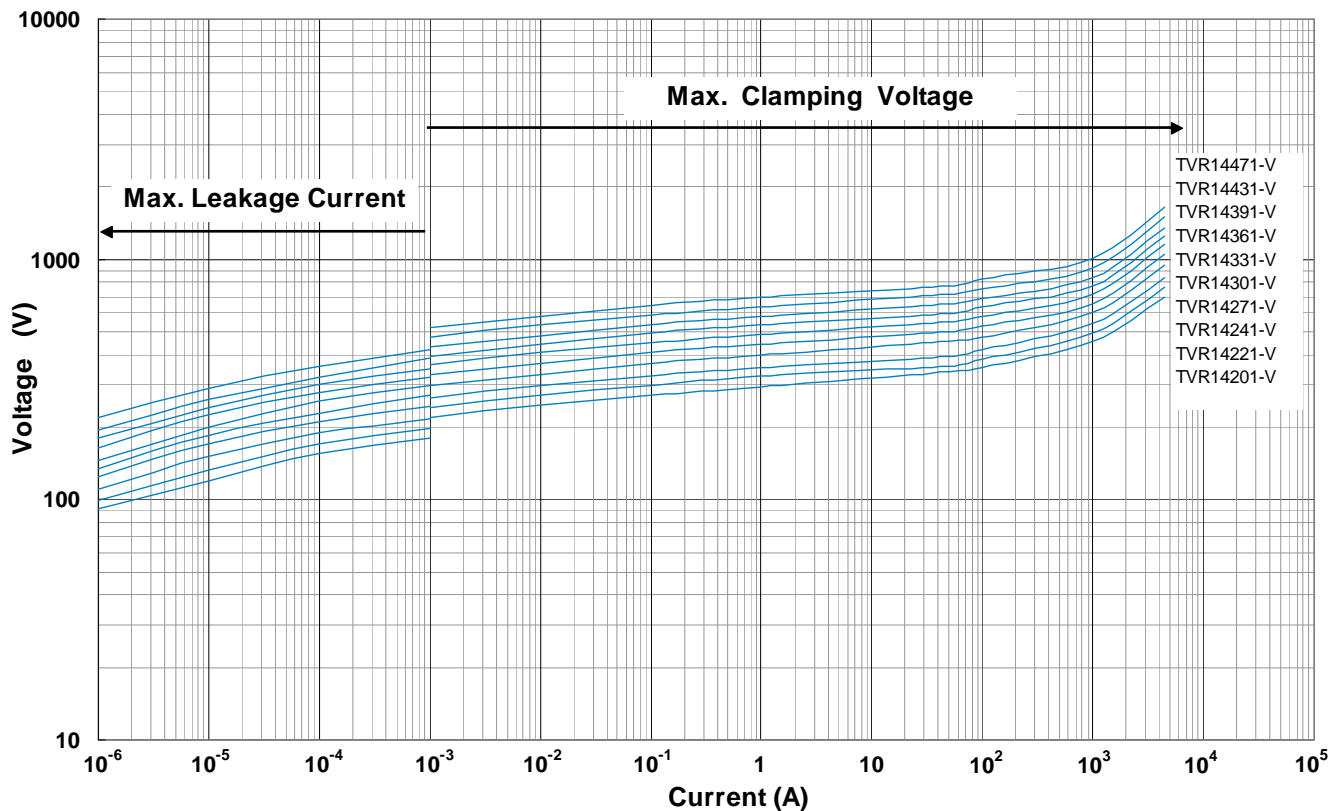

# Metal Oxide Varistor : TVR-V Series

## Multi-Surge Series



**Max. Leakage Current and Max. Clamping Voltage Curves ( TVR 14 511-V~ TVR 14 112-V )**

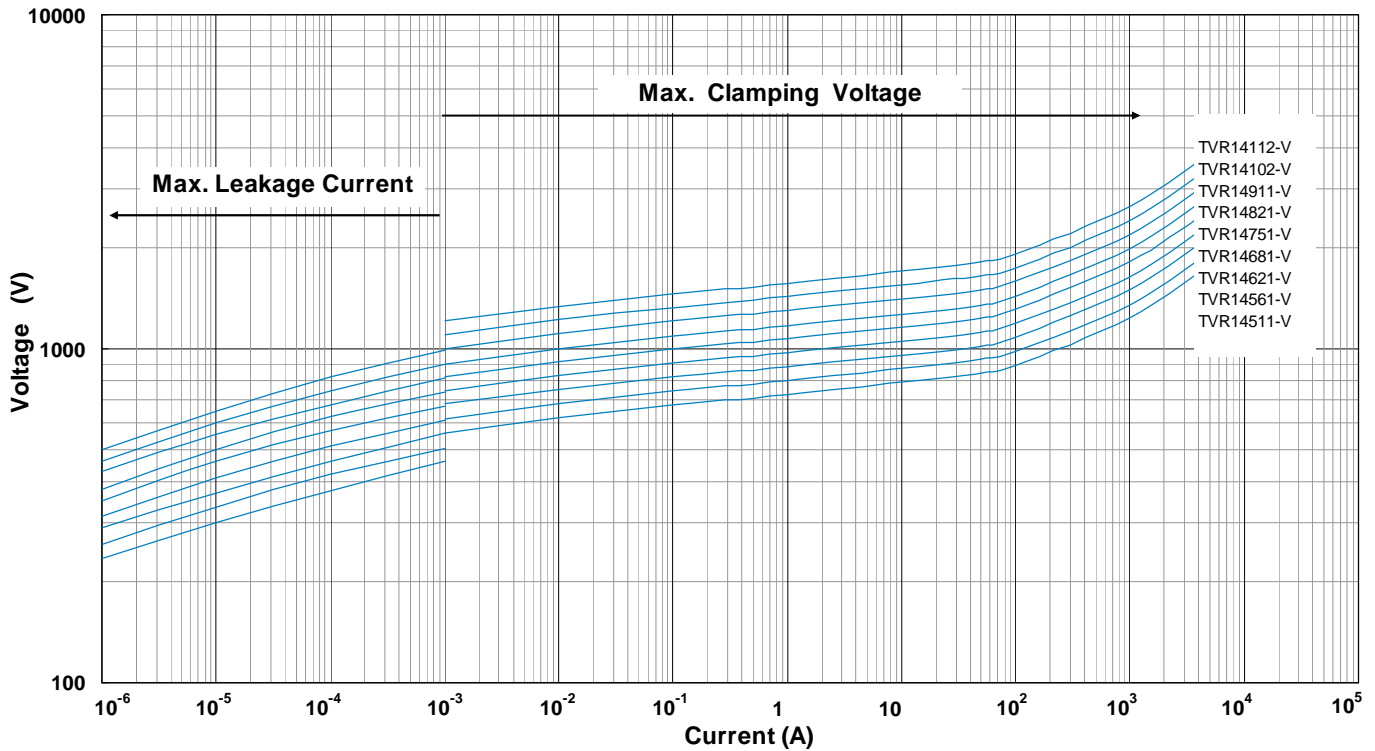

### ■ Soldering Recommendation

#### ● Wave Soldering Profile

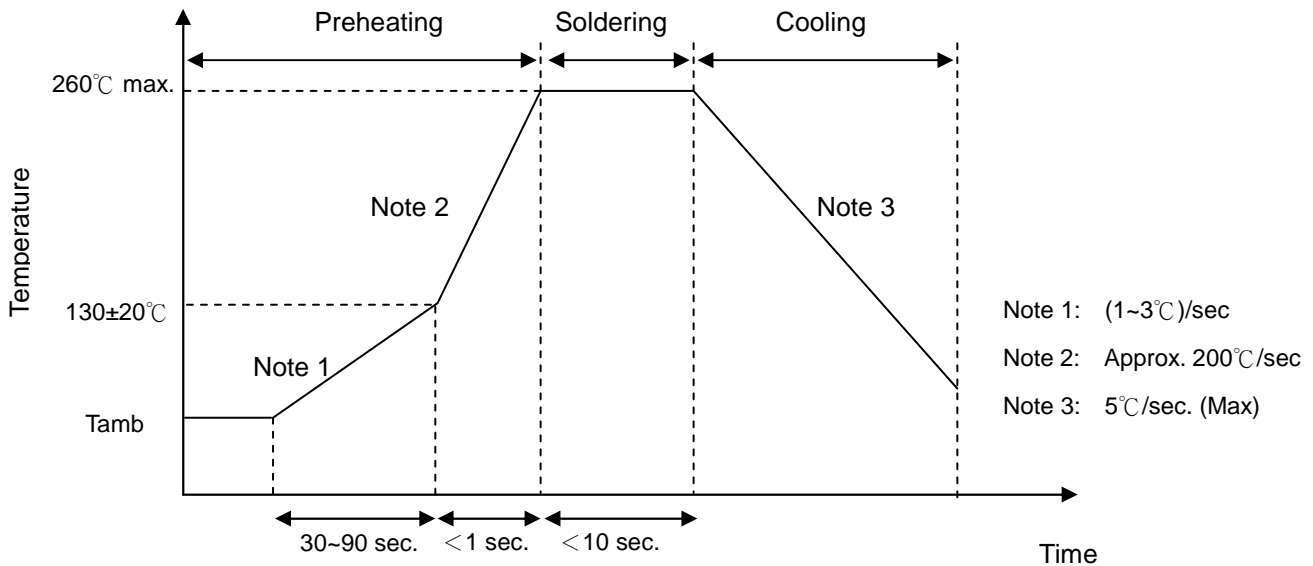

#### ● Recommended Reworking Conditions with Soldering Iron

Item	Conditions
Temperature of Soldering Iron-tip	360°C (max.)
Soldering Time	3 sec (max.)
Distance from Varistor	2 mm (min.)

# Metal Oxide Varistor : TVR-V Series

## Multi-Surge Series



### ■ Reliability

Item	Standard	Test conditions / Methods	Specifications															
Tensile Strength of Terminals	IEC60068-2-21	Gradually apply the force specified and keep the unit fixed for 10±1 sec.  <table style="width:100%; border:none;"> <tr> <td style="text-align:center; border:none;">Terminal diameter (mm)</td> <td style="text-align:center; border:none;">Force (Kg)</td> </tr> <tr> <td style="text-align:center; border:none;">0.5&lt;d≤0.8</td> <td style="text-align:center; border:none;">1.0</td> </tr> <tr> <td style="text-align:center; border:none;">0.8&lt;d≤1.25</td> <td style="text-align:center; border:none;">2.0</td> </tr> <tr> <td style="text-align:center; border:none;">1.25&lt;d</td> <td style="text-align:center; border:none;">4.0</td> </tr> </table>	Terminal diameter (mm)	Force (Kg)	0.5<d≤0.8	1.0	0.8<d≤1.25	2.0	1.25<d	4.0	No visible damage   ΔV/V <sub>1mA</sub>   ≤5%							
Terminal diameter (mm)	Force (Kg)																	
0.5<d≤0.8	1.0																	
0.8<d≤1.25	2.0																	
1.25<d	4.0																	
Bending Strength of Terminals	IEC 60068-2-21	Hold specimen and apply the force specified below to each lead. Bend the specimen to 90°, then return to the original position. Repeat the procedure in the opposite direction.  <table style="width:100%; border:none;"> <tr> <td style="text-align:center; border:none;">Terminal diameter (mm)</td> <td style="text-align:center; border:none;">Force (Kg)</td> </tr> <tr> <td style="text-align:center; border:none;">0.5&lt;d≤0.8</td> <td style="text-align:center; border:none;">0.5</td> </tr> <tr> <td style="text-align:center; border:none;">0.8&lt;d≤1.25</td> <td style="text-align:center; border:none;">1.0</td> </tr> <tr> <td style="text-align:center; border:none;">1.25&lt;d</td> <td style="text-align:center; border:none;">2.0</td> </tr> </table>	Terminal diameter (mm)	Force (Kg)	0.5<d≤0.8	0.5	0.8<d≤1.25	1.0	1.25<d	2.0	No visible damage   ΔV/V <sub>1mA</sub>   ≤5%							
Terminal diameter (mm)	Force (Kg)																	
0.5<d≤0.8	0.5																	
0.8<d≤1.25	1.0																	
1.25<d	2.0																	
Vibration	IEC 1051-1	Frequency range: 10 ~ 55 Hz Amplitude: 0.75mm or 98 m/s <sup>2</sup> Direction:3 mutually perpendicular directions ,2hrs each.	ΔV/V <sub>1mA</sub>   ≤5% No visible damage															
Solderability	IEC 60068-2-20	245 ± 3 °C, 3 ± 0.3 sec	At least 95% of terminal electrode is covered by new solder															
Resistance to Soldering Heat	IEC 60068-2-20	260 ± 3 °C, 10 ± 1 sec	ΔV/V <sub>1mA</sub>   ≤ 5% No visible damage															
High Temperature Storage	IEC 60068-2-2	125±5°C x 1000±24 hrs	ΔV/V <sub>1mA</sub>   ≤ 5% No visible damage															
Damp Heat, Steady State	IEC 60068-2-3	a. 40±2°C, 90 ~ 95 % RH, 1344HRS b. 40±2°C, 90 ~ 95 % RH, at 10%Vdc, 1344 hrs	No visible damage   ΔV/V <sub>1mA</sub>   ≤ 5% Insulation Resistance ≥100MΩ															
Rapid Change of Temperature	IEC 60068-2-14	The conditions shown below shall be repeated 5 cycles <table border="1" style="width:100%; border-collapse: collapse;"> <thead> <tr> <th>Step</th> <th>Temperature (°C)</th> <th>Period (minutes)</th> </tr> </thead> <tbody> <tr> <td style="text-align:center;">1</td> <td style="text-align:center;">-40±3</td> <td style="text-align:center;">30±3</td> </tr> <tr> <td style="text-align:center;">2</td> <td style="text-align:center;">Room temperature</td> <td style="text-align:center;">5±3</td> </tr> <tr> <td style="text-align:center;">3</td> <td style="text-align:center;">85±2</td> <td style="text-align:center;">30±3</td> </tr> <tr> <td style="text-align:center;">4</td> <td style="text-align:center;">Room temperature</td> <td style="text-align:center;">5±3</td> </tr> </tbody> </table>	Step	Temperature (°C)	Period (minutes)	1	-40±3	30±3	2	Room temperature	5±3	3	85±2	30±3	4	Room temperature	5±3	ΔV/V <sub>1mA</sub>   ≤ 5% No visible damage
Step	Temperature (°C)	Period (minutes)																
1	-40±3	30±3																
2	Room temperature	5±3																
3	85±2	30±3																
4	Room temperature	5±3																
Endurance at Upper Category Temperature	IEC61051-4.20	85 ± 2°C, 1000 ± 24 hrs, at VDC or Vrms (Max. Operating Voltage)	ΔV/V <sub>1mA</sub>   ≤ 10% No visible damage															
Low Temperature Storage (Optional)	CECC42000	- 40±5°C, 1000±24 hrs	ΔV/V <sub>1mA</sub>   ≤ 5% No visible damage															
8/20μs Surge Life	CECC42000	10,000 pulses ( 8/20μs), unipolar, interval 10 secs, amplitude corr. to max. Surge current derating curves for 20μs	ΔV <sub>1mA</sub> /V <sub>1mA</sub>   ≤ 10% No visible damage															
Varistor Voltage Temp. Coefficient	Specification Standard	$\frac{V_{1mA} \text{ at } 85^{\circ}\text{C} - V_{1mA} \text{ at } 25^{\circ}\text{C}}{V_{1mA} \text{ at } 25^{\circ}\text{C}} \times \frac{1}{60} \times 100 (\% / ^{\circ}\text{C})$ $\frac{V_{1mA} \text{ at } -40^{\circ}\text{C} - V_{1mA} \text{ at } 25^{\circ}\text{C}}{V_{1mA} \text{ at } 25^{\circ}\text{C}} \times \frac{1}{65} \times 100 (\% / ^{\circ}\text{C})$	-0.05 ≤ TC ≤ 0.05(%/°C)															

# Metal Oxide Varistor : TVR-V Series



## Multi-Surge Series

### Reliability

Item	Standard	Test conditions / Methods	Specifications
10/1000 $\mu$ s Surge Life	CECC42000	10/1000 $\mu$ s waveform, 10 surge currents, unipolar, interval 2mins, amplitude corr. to max. surge current derating curves for 1000 $\mu$ S	$ \Delta V_{1mA}/V_{1mA}  \leq 10\%$ No visible damage
Surge Endurance	Specification Standard	6KV/3KA Combination Waveform (1.2/50+8/20us) @ Vac (90°). 25times for TVR10-V series 60times for TVR14-V series	No visible damage
Nominal Discharge Current Test	UL1449 3 <sup>rd</sup> 37A	3KA 8/20us waveform @ Vac (90°) for 15 Times. ( For TVR14-V series only)	$ \Delta V_{1mA}/V_{1mA}  \leq 10\%$ No visible damage
Voltage Proof	IEC61051-4.8	Metal balls method, 2500 Vac 1 min	No visible damage

### Packaging

#### Taping Specification S Type (Straight lead)

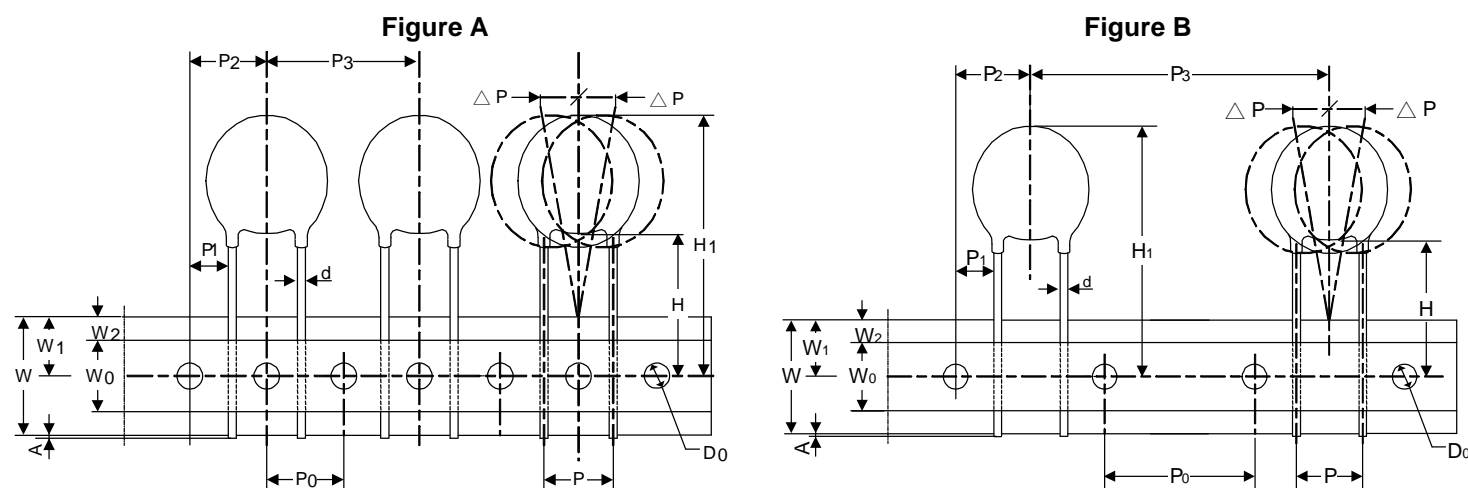

(Unit: mm)

Taping Code	Disc	P <sub>0</sub>	P	P <sub>1</sub>	P <sub>2</sub>	P <sub>3</sub>	H	H <sub>1</sub>	d	W <sub>0</sub>	W <sub>1</sub>	W <sub>2</sub>	W	ΔP	Δh	A	D <sub>0</sub>	t	Figure
	Size	±0.3	±1	±1	±1.3	±1	+2/-0	Max.	±0.02	±1	+0.75/-0.5	Max.	±1	Max.	Max.	Max.	±0.2	±0.2	
A (P <sub>0</sub> =12.7)	10	12.7	7.5	3.35	12.7	12.7	18	33.5	0.8	12	9	3	18	1	2	0.5	4	0.6	A
E (P <sub>0</sub> =15.0)	10	15	7.5	3.35	7.5	15	18	33.5	0.8	12	9	3	18	1	2	0.5	4	0.6	B
A (P <sub>0</sub> =12.7)	14	12.7	7.5	8.55	12.7	25.4	18	38	0.8	12	9	3	18	1	2	0.5	4	0.6	A
E (P <sub>0</sub> =15.0)	14	15	7.5	3.35	7.5	30	18	38	0.8	12	9	3	18	1	2	0.5	4	0.6	B

# Metal Oxide Varistor : TVR-V Series



## Multi-Surge Series

### F Type (Y kink lead)

Figure A

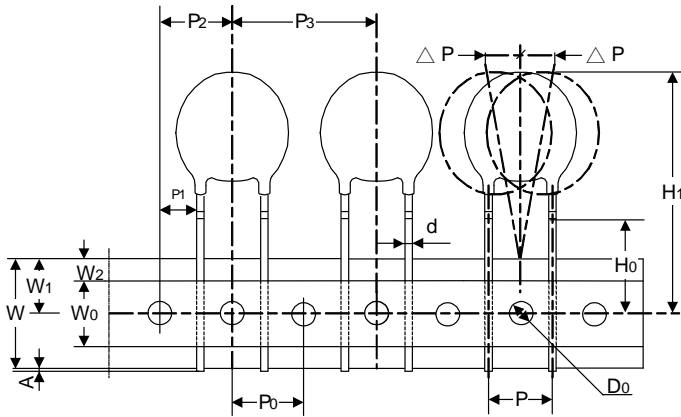
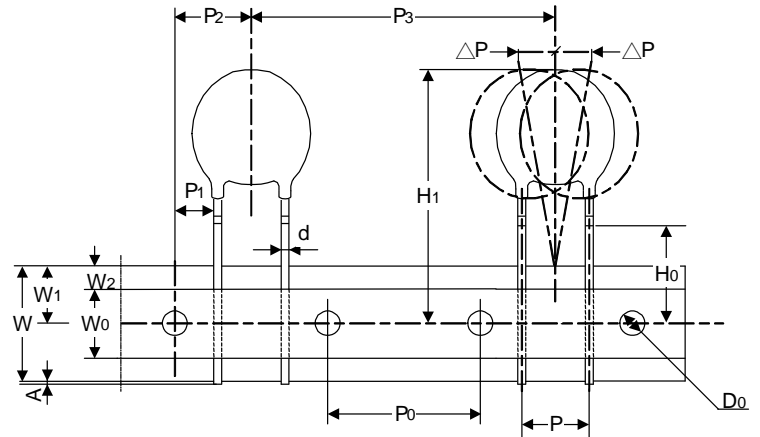

Figure B



(Unit: mm)

Taping Code	Disc	P <sub>0</sub>	P	P <sub>1</sub>	P <sub>2</sub>	P <sub>3</sub>	H	H <sub>1</sub>	d	W <sub>0</sub>	W <sub>1</sub>	W <sub>2</sub>	W	ΔP	Δh	A	D <sub>0</sub>	t	Figure
	Size	±0.3	±1	±1	±1.3	±1	±0.5	Max.	±0.02	±1	+0.75/ -0.5	Max.	±1	Max.	Max.	Max.	±0.2	±0.2	
A (P <sub>0</sub> =12.7)	10	12.7	7.5	3.35	12.7	12.7	16	33.5	0.8	12	9	3	18	1	2	0.5	4	0.6	A
E (P <sub>0</sub> =15.0)	10	15	7.5	3.35	7.5	15	16	33.5	0.8	12	9	3	18	1	2	0.5	4	0.6	B
A (P <sub>0</sub> =12.7)	14	12.7	7.5	8.55	12.7	25.4	16	38	0.8	12	9	3	18	1	2	0.5	4	0.6	A
E (P <sub>0</sub> =15.0)	14	15	7.5	3.35	7.5	30	16	38	0.8	12	9	3	18	1	2	0.5	4	0.6	B

### Quantity

#### Bulk Packing

Disc Size/mm	Quantity pcs/ bag
Φ10-V	200
Φ14-V	100

#### Reel Packing

Disc Size/mm	Quantity pcs/reel
Φ10(201~911)-V	1000
Φ10(102~112)-V	750
TVR14(201~391)-V	750
TVR14(431~112)-V	500

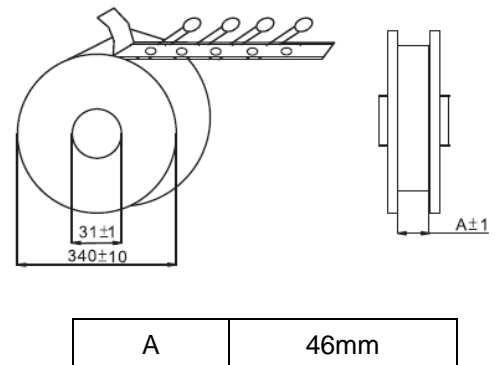

# Metal Oxide Varistor : TVR-V Series



## Multi-Surge Series

### ● Ammo Packing

Disc Size/mm	Quantity pcs/ box
Φ10(201~361)-V	750
Φ10(391~621)-V	500
Φ10(681~112)-V	400
TVR14(201~271)-V	500
TVR14(301~112)-V	250

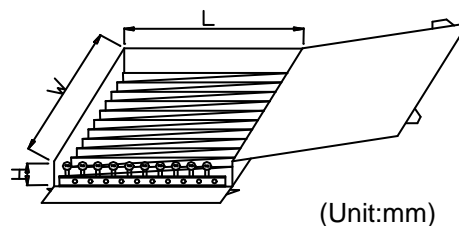

(Unit:mm)

Disc Size	W±5	L±5	H±5
Φ10-V	348	275	60
Φ14-V	348	185	60

### ■ Storage Conditions of Products

- Storage Conditions :
  1. Storage Temperature : -10°C ~ +40°C
  2. Relative Humidity : ≤ 75%RH
  3. Keep away from corrosive atmosphere and sunlight
- Period of Storage: 1 year.