

# CPTC Thermistor : TPM Type

## SMD CPTC Thermistor for Temperature Sensing



### ■ Features

1. RoHS compliant
2. Thermistor chip with lead-free tinned terminals
3. EIA size 0402,0603,0805
4. Fast and reliable response
5. Suitable for reflow soldering
6. Agency Recognition: UL & cUL

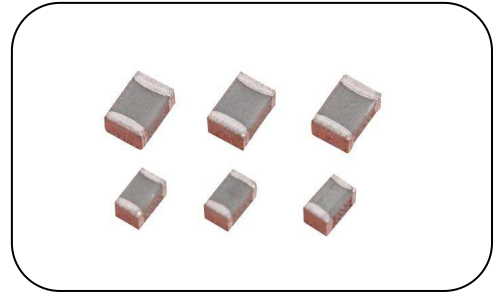

### ■ Recommended Applications

1. DC/DC converters
2. AC Adapter
3. Inverter
4. Overheat protection for transistor and ICs

### ■ Part Number Code

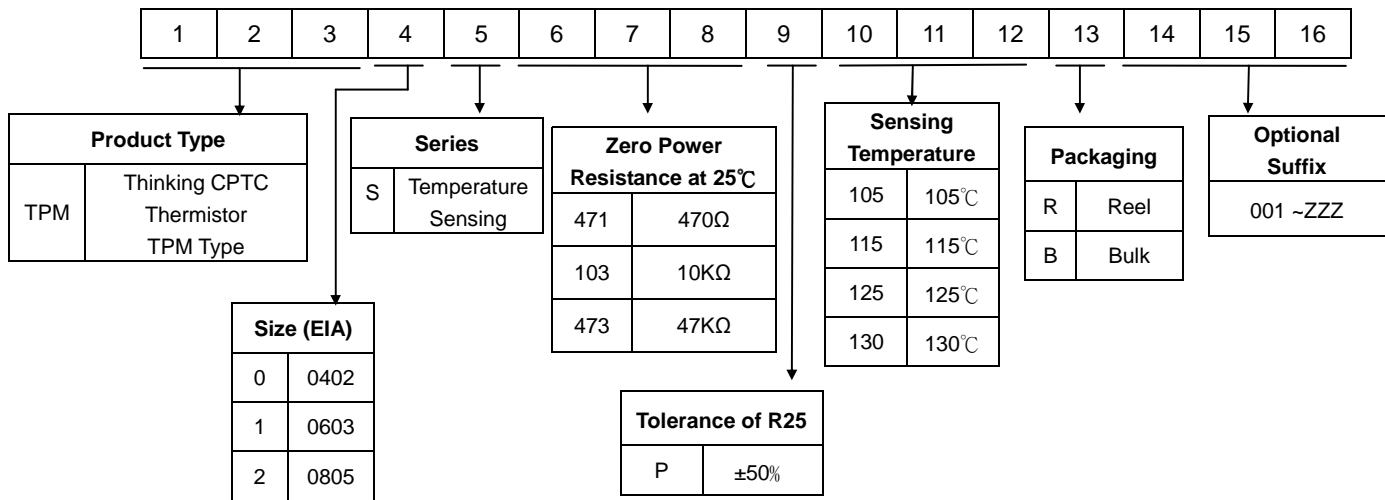

### ■ Structure and Dimensions

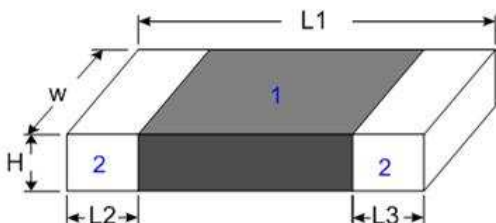

(Unit: mm)

Part No.	Size (EIA)	L1	W	H max.	L2 and L3.
TPM0	0402	1.00±0.15	0.50±0.10	0.6	0.20±0.10
TPM1	0603	1.60±0.15	0.80±0.15	0.95	0.40±0.20
TPM2	0805	2.00±0.20	1.25±0.20	1.2	0.45±0.25

Note1: Material of body: PTC Thermistor Ceramics  
 Note2: Electrode: Ag-Zn/Ni/Sn

# CPTC Thermistor : TPM Type

## SMD CPTC Thermistor for Temperature Sensing



### ■ Electrical Characteristics

Part No.	Size (EIA)	Sensing Temperature (°C)	Resistance (Ω)			Max. Voltage (V)	Operating Temperature Range(°C)	Safety Approvals	
		Ts	25°C	Ts - 5°C	Ts + 5°C			V <sub>dc</sub>	T <sub>L</sub> ~T <sub>U</sub>
TPM0S471P105R	0402	105±5	470	≤4,700	≥4,700	32	-25~+120	√	√
TPM0S471P115R		115±5					-25~+130	√	√
TPM0S471P125R		125±5					-25~+140	√	√
TPM1S471P065R	0603	65±5	470	≤4,700	≥4,700	32	-25~+80	√	√
TPM1S471P075R		75±5					-25~+90	√	√
TPM1S471P085R		85±5					-25~+100	√	√
TPM1S471P095R		95±5					-25~+110	√	√
TPM1S471P105R		105±5					-25~+120	√	√
TPM1S471P115R		115±5					-25~+130	√	√
TPM1S471P125R		125±5					-25~+140	√	√
TPM1S471P135R		135±5					-25~+150	√	√
TPM1S103P110R	0603	110±5	10K	≤4.7M	≥4.7M	32	-25~+125	√	√
TPM1S103P120R		120±5					-25~+135	√	√
TPM1S103P130R		130±5					-25~+145	√	√
TPM1S473P130R		130±5	47K	≤4.7M	≥4.7M		-25~+145	√	√
TPM2S471P065R	0805	65±5	470	≤4,700	≥4,700	32	-25~+80	√	√
TPM2S471P075R		75±5					-25~+90	√	√
TPM2S471P085R		85±5					-25~+100	√	√
TPM2S471P095R		95±5					-25~+110	√	√
TPM2S471P105R		105±5					-25~+120	√	√
TPM2S471P115R		115±5					-25~+130	√	√
TPM2S471P125R		125±5					-25~+140	√	√
TPM2S471P135R		135±5					-25~+150	√	√

Note: UL&cUL File No. E138827

# CPTC Thermistor : TPM Type

## SMD CPTC Thermistor for Temperature Sensing



### ■ Resistance-Temperature Characteristics (Typical)

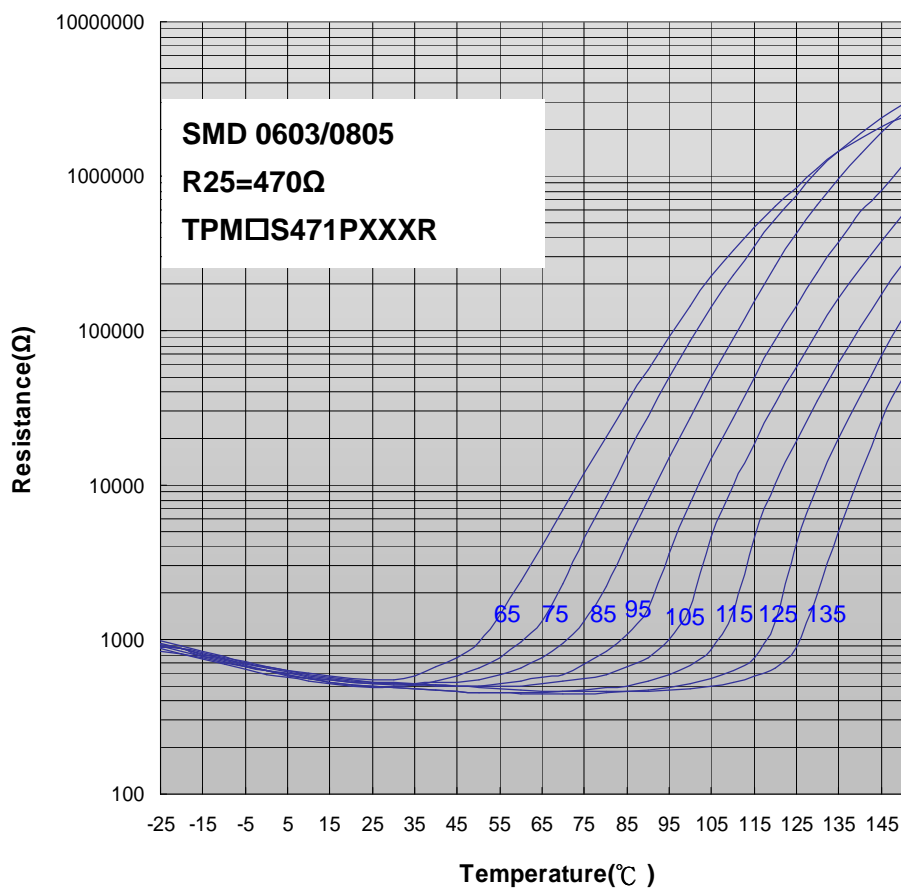
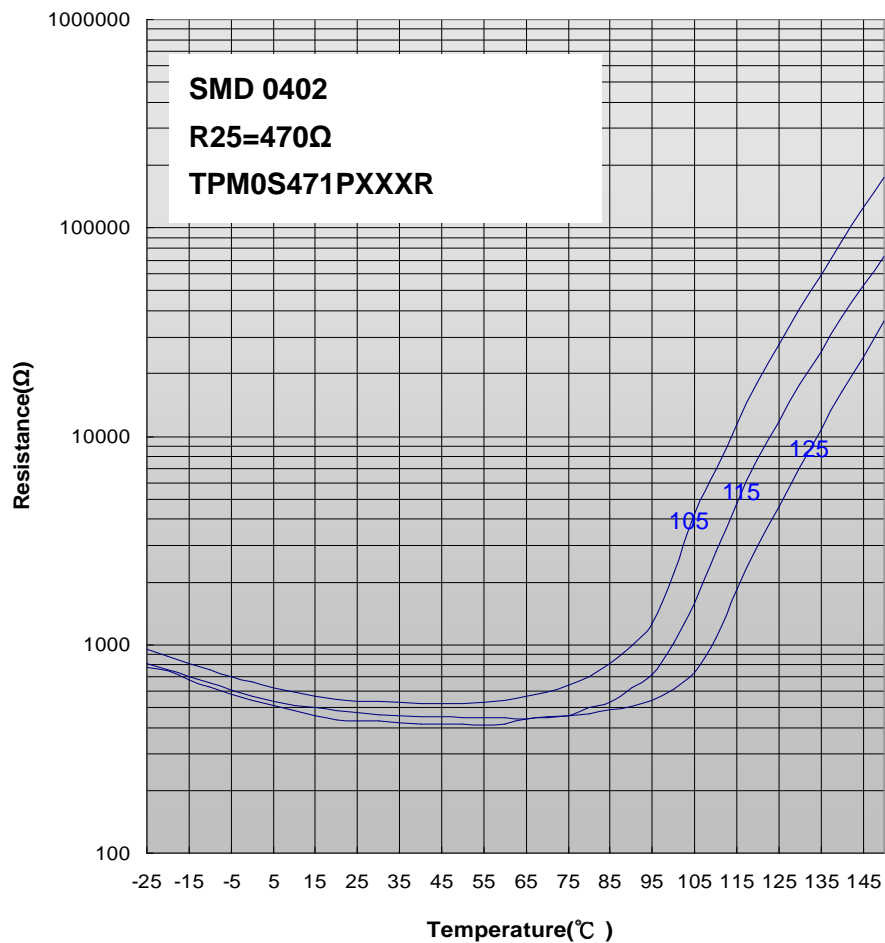

# CPTC Thermistor : TPM Type

## SMD CPTC Thermistor for Temperature Sensing



### ■ Resistance-Temperature Characteristics (Typical)

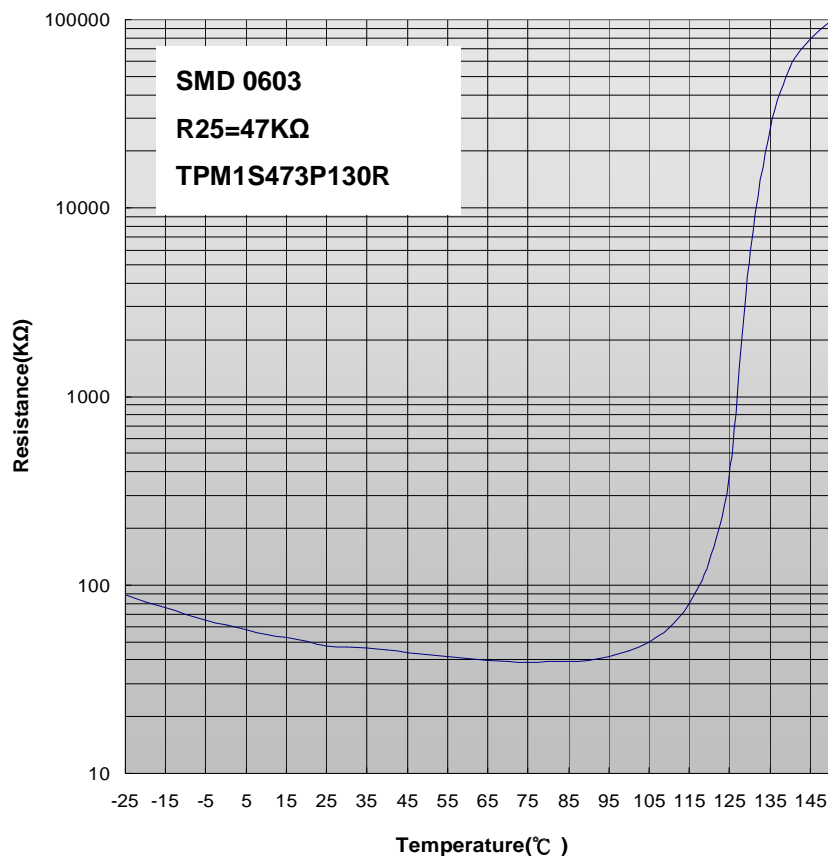
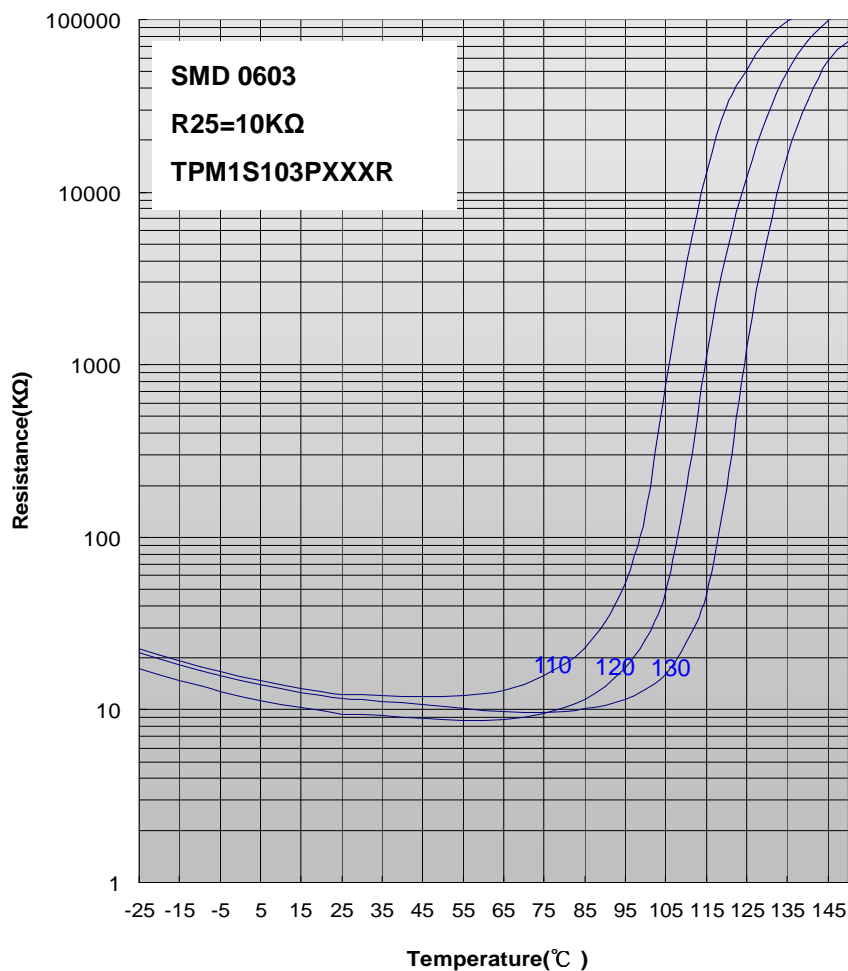

# CPTC Thermistor : TPM Type

## SMD CPTC Thermistor for Temperature Sensing



### ■ Typical Application Circuit

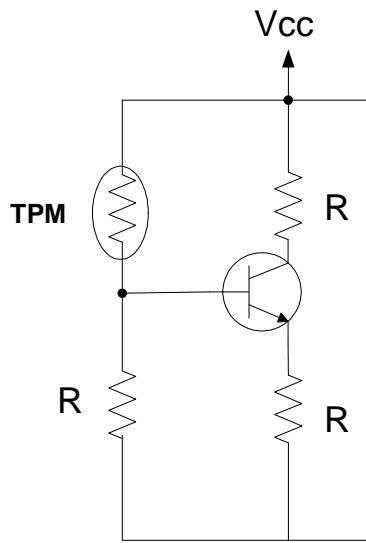

Fig 1. Overheat Protection

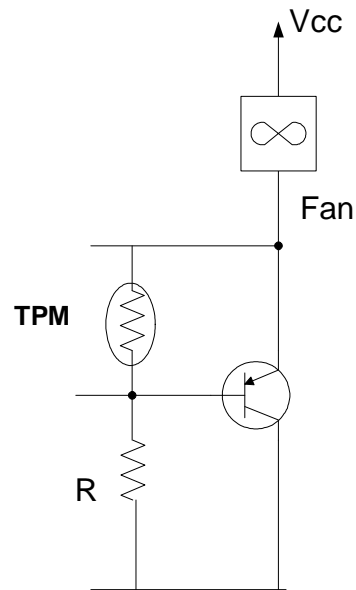

Fig 2. Temp. Sensing and Control

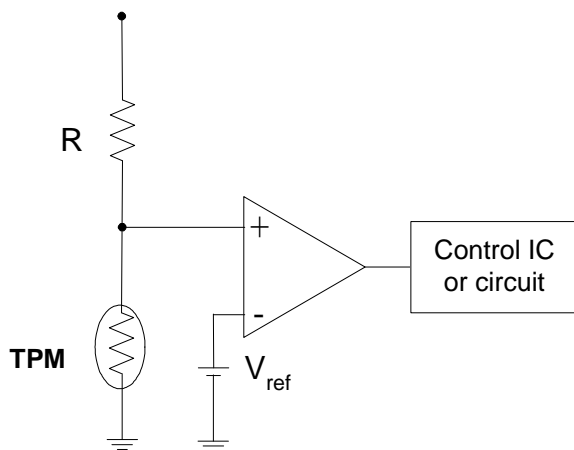

Fig 3. Comparator Circuit

# CPTC Thermistor : TPM Type

## SMD CPTC Thermistor for Temperature Sensing



### Soldering Recommendation

#### ■ IR-Reflow Soldering Profile

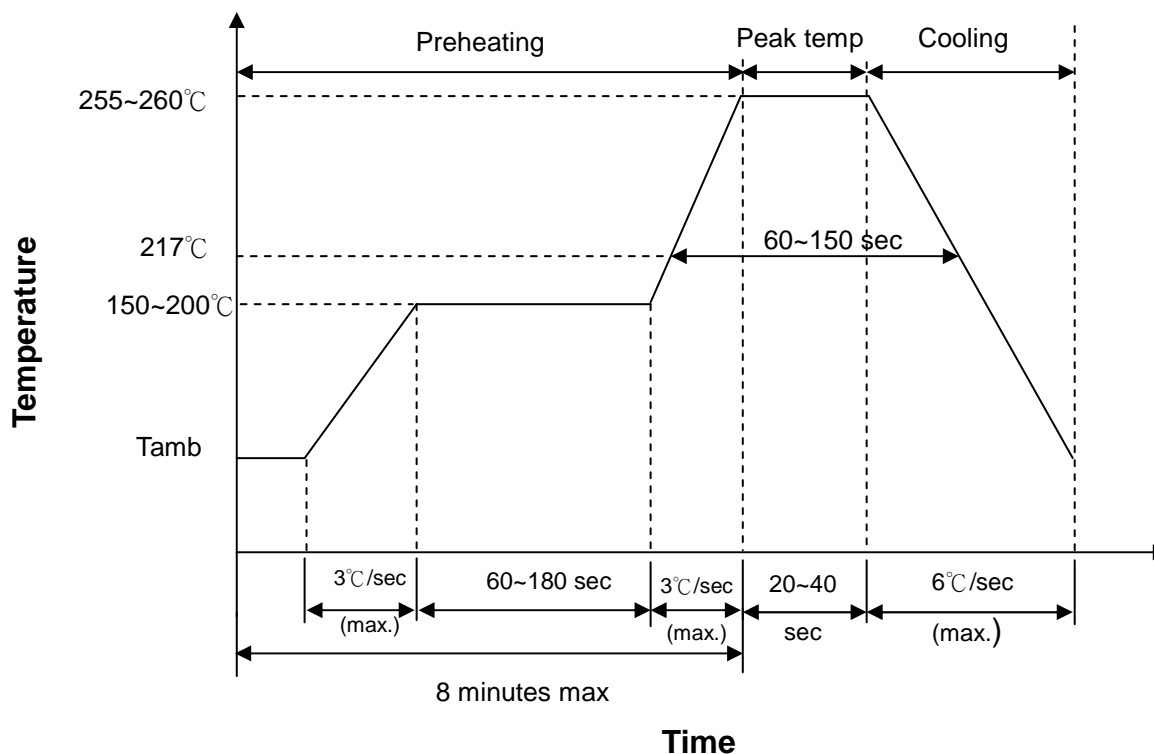

#### ■ Reworking Conditions With Soldering Iron

Item	Conditions
Temperature of Soldering Iron-tip	360°C (max.)
Diameter of Soldering Iron-tip	Φ3mm (max.)
Soldering Time	3 sec (max.)

# CPTC Thermistor : TPM Type

## SMD CPTC Thermistor for Temperature Sensing



### ■ Recommended Pad Dimensions

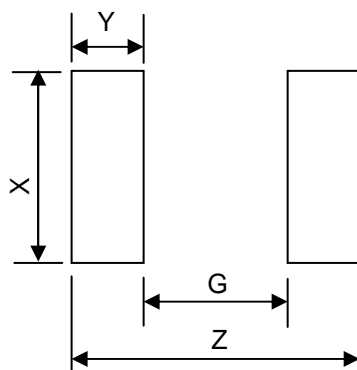

Size	Z (mm)	G (mm)	X (mm)	Y (mm)
0402	2.1~2.2	0.4~0.5	0.6~0.7	0.9~1.0
0603	2.7~2.8	0.6~0.7	0.9~1.0	1.0~1.1
0805	3.1~3.2	0.6~0.7	1.4~1.5	1.2~1.3

Followed Standard:IPC-SM-782A

### ■ Reliability

Item	Standard	Test Conditions / Methods	Specifications															
Bending Strength	IEC-60068-2-21	Warp 3mm Speed < 0.5mm/sec. Duration: 10 sec on PCB.	No visible damage $ \Delta R_{25}/R_{25}  \leq 10\%$															
Damp Heat, Steady State	IEC 60068-2-3	$40 \pm 2\text{ }^{\circ}\text{C}$ , 90 ~ 95% RH , 1000± 24 HRS	No visible damage $ \Delta R_{25}/R_{25}  \leq 20\%$ ( $ \Delta R_{25}/R_{25}  \leq 30\%$ *1)															
High Temp. Storage	IEC 60738-1 IEC 60068-2-2	Tu. $\pm 5\text{ }^{\circ}\text{C}$ , 1000 ± 24 HRS	No visible damage $ \Delta R_{25}/R_{25}  \leq 20\%$ ( $ \Delta R_{25}/R_{25}  \leq 30\%$ *1)															
Rapid Change of Temperature	IEC 60068-2-14	The conditions shown below shall be repeated 5 cycles on PCB <table border="1"> <thead> <tr> <th>Step</th> <th>Temperature (<math>^{\circ}\text{C}</math>)</th> <th>Period (minutes)</th> </tr> </thead> <tbody> <tr> <td>1</td> <td><math>-25 \pm 5</math></td> <td><math>30 \pm 3</math></td> </tr> <tr> <td>2</td> <td>Room temperature</td> <td><math>5 \pm 3</math></td> </tr> <tr> <td>3</td> <td><math>150 \pm 5</math></td> <td><math>30 \pm 3</math></td> </tr> <tr> <td>4</td> <td>Room temperature</td> <td><math>5 \pm 3</math></td> </tr> </tbody> </table>	Step	Temperature ( $^{\circ}\text{C}$ )	Period (minutes)	1	$-25 \pm 5$	$30 \pm 3$	2	Room temperature	$5 \pm 3$	3	$150 \pm 5$	$30 \pm 3$	4	Room temperature	$5 \pm 3$	No visible damage $ \Delta R_{25}/R_{25}  \leq 20\%$ ( $ \Delta R_{25}/R_{25}  \leq 30\%$ *1)
Step	Temperature ( $^{\circ}\text{C}$ )	Period (minutes)																
1	$-25 \pm 5$	$30 \pm 3$																
2	Room temperature	$5 \pm 3$																
3	$150 \pm 5$	$30 \pm 3$																
4	Room temperature	$5 \pm 3$																
High Temp. Load	IEC 60738-1	$85 \pm 5\text{ }^{\circ}\text{C}$ Vmax. , 1000 ± 24 HRS	No visible damage $ \Delta R_{25}/R_{25}  \leq 20\%$ ( $ \Delta R_{25}/R_{25}  \leq 30\%$ *1)															

# CPTC Thermistor : TPM Type

## SMD CPTC Thermistor for Temperature Sensing



Item	Standard	Test Conditions / Methods	Specifications
Climatic Sequence	IEC 60738-1	a. Tu. x 16 HRS b. 1st cycle : 40 °C 95 %RH x 24 HRS c. -25 °C x 2 HRS d. 5 cycles : 40°C 95% RH x 24 HRS / Cycle	No visible damage $ \Delta R_{25}/R_{25}  \leq 20\%$ ( $ \Delta R_{25}/R_{25}  \leq 30\%$ * <sup>1</sup> )
Solderability	IEC 60068-2-2	235 ± 5 °C , 2 ± 0.5 sec	At least 95% of terminal electrode is covered by new solder
Resistance to Soldering Heat	IEC 60068-2-2	260 ± 5 °C , 10 ± 1 sec	No visible damage $ \Delta R_{25}/R_{25}  \leq 20\%$ ( $ \Delta R_{25}/R_{25}  \leq 30\%$ * <sup>1</sup> )
Low Temp. Storage* <sup>1</sup>	Specification Standard	-40 ± 3 °C , 1000 ± 24 HRS	No visible damage $ \Delta R_{25}/R_{25}  \leq 30\%$ * <sup>1</sup>

\*1 : Apply for TPM1S103□110R , TPM1S103□120R , TPM1S103□130R , and TPM1S473□130R only.

### ■ Package

#### ● Taping Specification

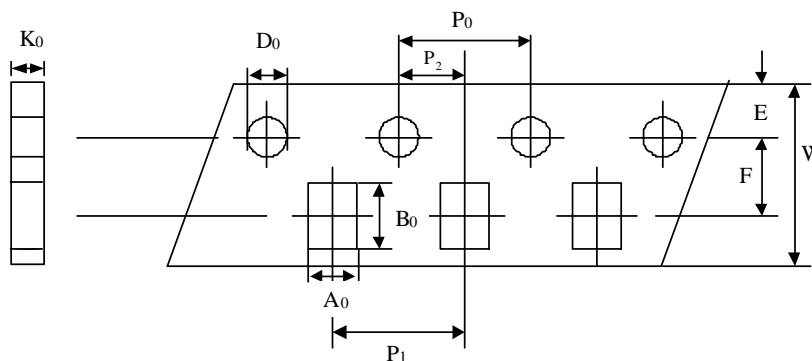

(Unit: mm)

Index Type	$A_0$	$B_0$	W	E	F	$P_1$	$P_2$	$P_0$	$D_0$	$K_0$
	±0.05	±0.12	±0.2	±0.1	±0.05	±0.1	±0.05	±0.1	±0.1	±0.1
0402	0.62	1.12	8	1.75	3.5	2	2	4	1.55	0.60

Index Type	$A_0$	$B_0$	W	E	F	$P_1$	$P_2$	$P_0$	$D_0$	$K_0$
	±0.2	±0.2	±0.2	±0.1	±0.05	±0.1	±0.05	±0.1	±0.1	±0.1
0603	1.1	1.9	8	1.75	3.5	4	2	4	1.55	0.95
0805	1.5	2.3	8	1.75	3.5	4	2	4	1.55	0.95

# CPTC Thermistor : TPM Type

## SMD CPTC Thermistor for Temperature Sensing



- Quantity

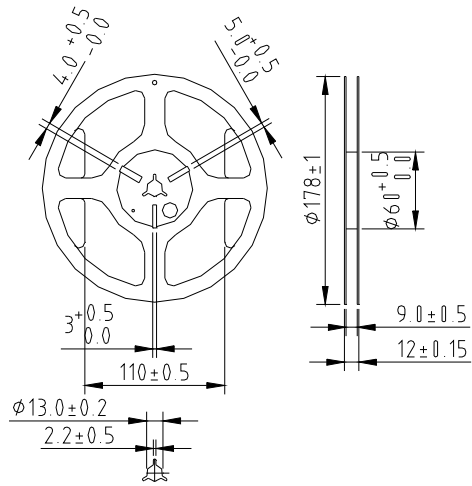

Type	Quantity(pcs/reel)
0402	10000
0603	4000
0805	3500

### ■ Storage Condition of Products

- Storage Conditions :
  1. Storage Temperature:  $-10^{\circ}\text{C} \sim +40^{\circ}\text{C}$
  2. Relative Humidity:  $\leq 75\% \text{RH}$
  3. Keep away from corrosive atmosphere and sunlight.
- Period of Storage : 1 year

# CPTC Thermistor : TPM Type

## SMD CPTC Thermistor for Temperature Sensing



### ■ Cross Reference

Size (EIA)	R25	Sensing Temperature	THINKING Part Number	Murata Part Number	EPCOS Part Number	
		Ts (°C)				
0402	470Ω	105±5	TPM0S471P105R	PRF15BC471QB1RC	----	
		115±5	TPM0S471P115R	PRF15BB471QB1RC	----	
		125±5	TPM0S471P125R	PRF15BA471QB1RC	----	
0603	470Ω	65±5	TPM1S471P065R	PRF18BG471QB1RB	----	
		75±5	TPM1S471P075R	PRF18BF471QB1RB	B59601A075A062	
		85±5	TPM1S471P085R	PRF18BE471QB1RB	B59601A0085A062	
		95±5	TPM1S471P095R	PRF18BD471QB1RB	B59601A0095A062	
		105±5	TPM1S471P105R	PRF18BC471QB1RB	B59601A0105A062 B59601A0110A062(OLD PART)	
		115±5	TPM1S471P115R	PRF18BB471QB1RB	B59601A0115A062 B59601A0120A062(OLD PART)	
		125±5	TPM1S471P125R	PRF18BA471QB1RB	B59601A0125A062 B59601A0130A062(OLD PART)	
		135±5	TPM1S471P135R	PRF18AR471QB1RB	B59601A0135A062	
	10KΩ	110±5	TPM1S103P110R	----	----	
		120±5	TPM1S103P120R	----	----	
		130±5	TPM1S103P130R	PRF18BA103QB1RB	----	
	47KΩ	130±5	TPM1S473P130R	PRF18BA473QB1RB	----	
	0805	470Ω	65±5	TPM2S471P065R	-----	B59701A0070A062
			75±5	TPM2S471P075R	-----	-----
85±5			TPM2S471P085R	PRF21BE471QB1RA	B59701A0090A062	
95±5			TPM2S471P095R	PRF21BD471QB1RA	B59701A0100A062	
105±5			TPM2S471P105R	PRF21BC471QB1RA	B59701A0110A062	
115±5			TPM2S471P115R	PRF21BB471QB1RA	B59701A0120A062	
125±5			TPM2S471P125R	PRF21BA471QB1RA	B59701A0130A062	
135±5			TPM2S471P135R	PRF21AR471QB1RA	-----	