

PTC Thermistor for Automotive : TPM-C Series

SMD PTC Thermistor for Temperature Sensing



■ Features

1. Qualification based on AEC-Q200 Rev-C
2. RoHS & Halogen-free compliant
3. EIA size 0603,0805
4. Fast and reliable response

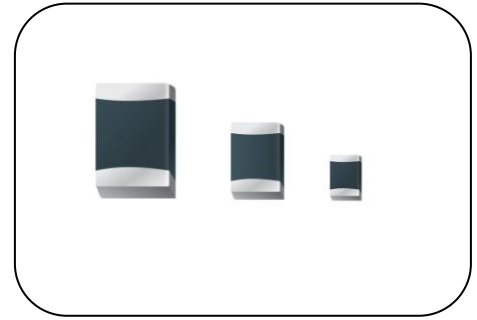

■ Recommended Applications

1. Automotive electronics

■ Part Number Code

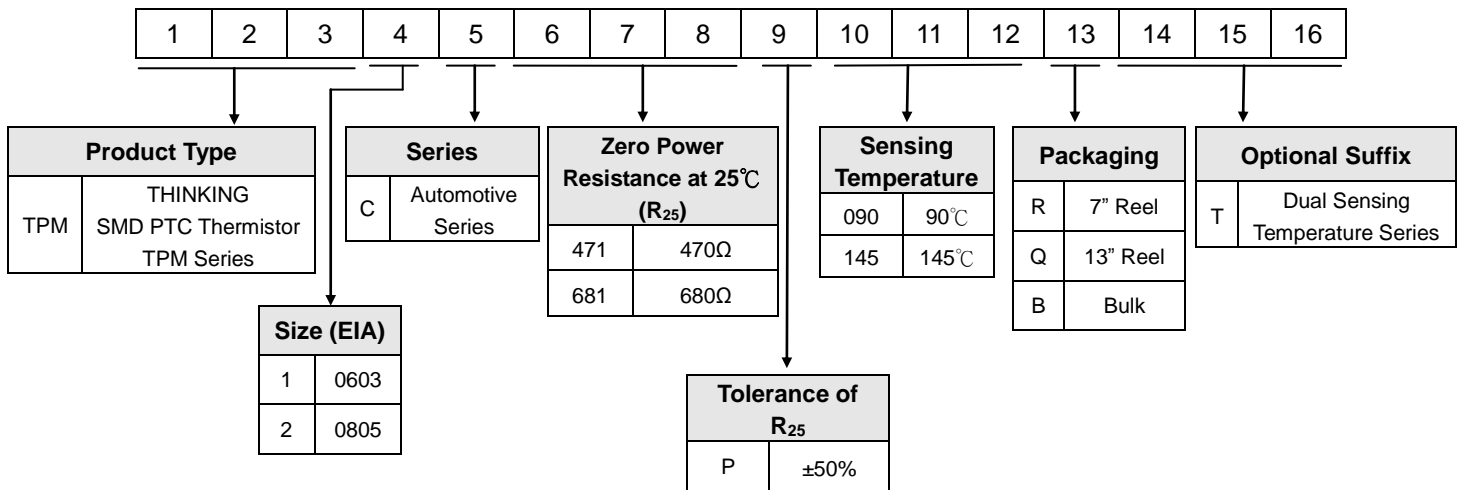

■ Structure and Dimensions

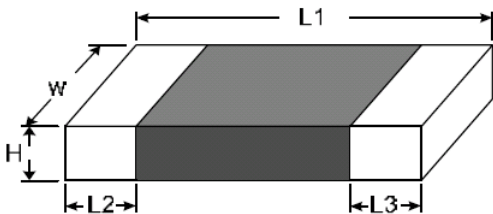

(Unit: mm)

Part No.	Size (EIA)	L1	W	H max.	L2 and L3
TPM1	0603	1.60±0.15	0.80±0.15	0.95	0.40±0.20
TPM2	0805	2.00±0.20	1.25±0.20	1.00	0.45±0.25

PTC Thermistor for Automotive : TPM-C Series

SMD PTC Thermistor for Temperature Sensing



■ Electrical Characteristics

● 0603 Series

Part No.	Size (EIA)	Sensing Temperature at 4.7K Ω	Zero Power Resistance at 25 $^{\circ}$ C	Max. Voltage (V)	Operating Temperature Range
		Ts	R25	Vmax	T _L ~T _U
		($^{\circ}$ C)	(Ω)	(V _{DC})	($^{\circ}$ C)
TPM1C471P075R	0603	75 \pm 5	470	32	-40 ~ +90
TPM1C471P105R		105 \pm 5	470	32	-40 ~ +120
TPM1C471P115R		115 \pm 5	470	32	-40 ~ +130

● Dual Sensing Temperature 0603 Series

Part No.	Size (EIA)	Zero Power Resistance at 25 $^{\circ}$ C	Sensing Temperature 1 at 4.7 K Ω	Sensing Temperature 2 at 47 K Ω	Max. Voltage	Operating Temperature Range
		R25	Ts1	Ts2	Vmax	T _L ~T _U
		(Ω)	($^{\circ}$ C)	($^{\circ}$ C)	(V _{DC})	($^{\circ}$ C)
TPM1C471P075RT	0603	470	75 \pm 5	90 \pm 7	32	-40 ~ +100
TPM1C471P105RT		470	105 \pm 5	120 \pm 7	32	-40 ~ +130
TPM1C471P115RT		470	115 \pm 5	130 \pm 7	32	-40 ~ +140

Note: T = Dual Sensing Temperature Series

● 0805 Series

Part No.	Size (EIA)	Sensing Temperature	Resistance				Max. Voltage (V)	Operating Temperature Range
		Ts	R25	Ts - 5 $^{\circ}$ C	Ts + 5 $^{\circ}$ C	Ts + 15 $^{\circ}$ C	Vmax	T _L ~T _U
		($^{\circ}$ C)	(Ω)	(K Ω)	(K Ω)	(K Ω)	(V _{DC})	($^{\circ}$ C)
TPM2C681P090R	0805	90	680	\leq 5.5	\geq 13.3	\geq 40	32	-40 ~ +125
TPM2C681P100R		100						-40 ~ +125
TPM2C681P110R		110						-40 ~ +135

PTC Thermistor for Automotive : TPM-C Series

SMD PTC Thermistor for Temperature Sensing



Resistance-Temperature Characteristics (Typical)

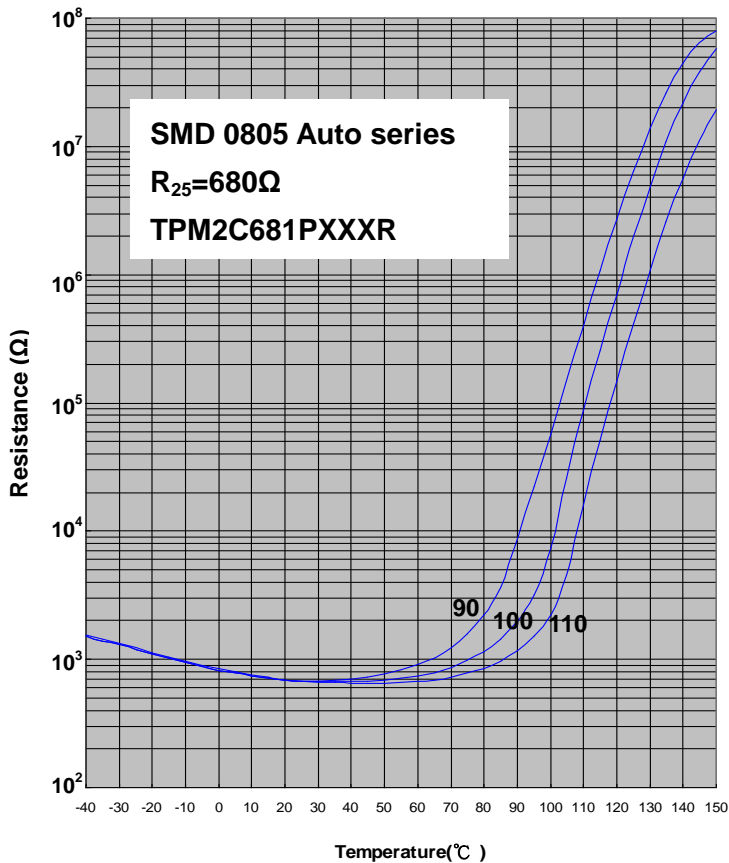
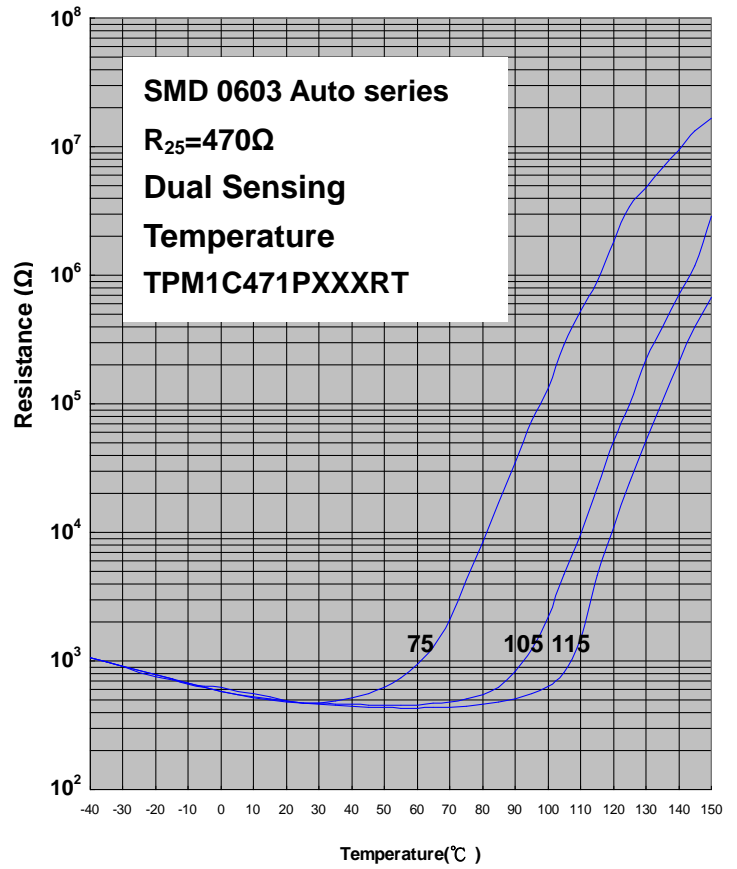
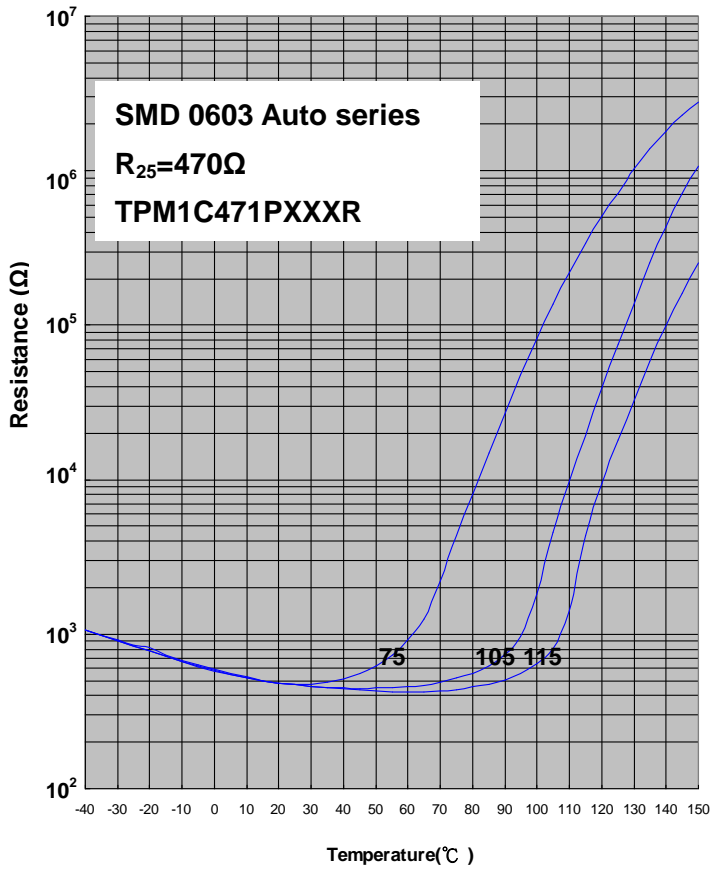

PTC Thermistor for Automotive : TPM-C Series

SMD PTC Thermistor for Temperature Sensing



■ Soldering Recommendation

● IR-Reflow Soldering Profile

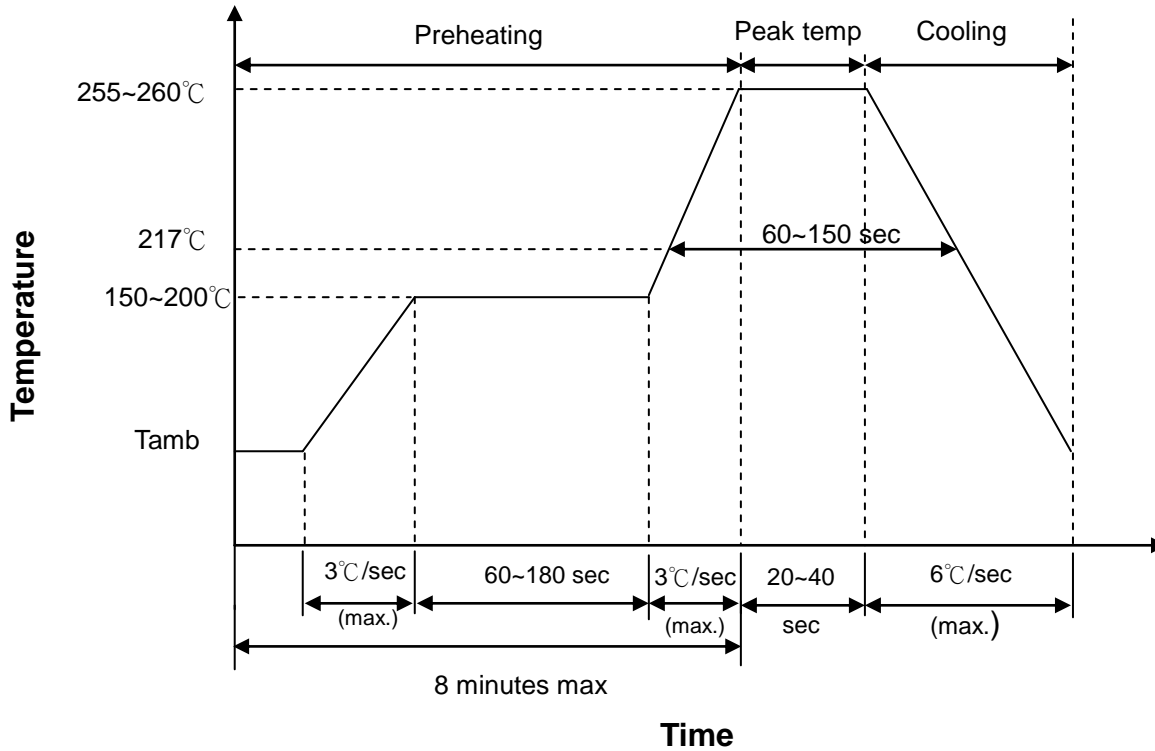

● Recommended Reworking Conditions with Soldering Iron

Item	Conditions
Temperature of Soldering Iron-tip	360°C (max.)
Soldering Time	3 sec (max.)
Diameter of Soldering Iron-tip	Φ3mm (max.)
Caution: Please do not touch the component surface with soldering iron directly to prevent component damage.	

■ Recommended Soldering Pad Dimensions

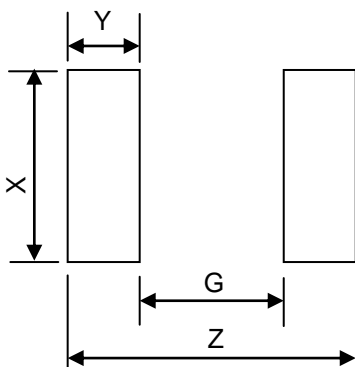

Size (EIA)	Z (mm)	G (mm)	X (mm)	Y (mm)
0603	3.0	1.0	1.0	1.0
0805	3.4	1.0	1.4	1.2

PTC Thermistor for Automotive : TPM-C Series

SMD PTC Thermistor for Temperature Sensing



■ Reliability (based on AEC-Q200 Rev-C)

Item	Standard	Test Conditions / Methods	Specifications																																										
High Temperature Exposure (Storage)	MIL-STD-202 Method 108	Test temp.: T _{max} . +3/-0°C Duration: 1000 hrs unpowered Measurement at 24±2 hours after test conclusion.	No visible damage ΔR ₂₅ /R ₂₅ ≤ 20%																																										
Temperature Cycling	JESD22 Method JA-104	Lower test temp.: -40 +0/-3°C Upper test temp.: 125 +3/-0°C Soak time at lower or upper temp.: 1 min Cycle time : 2 cycles/hr Number of cycles: 1000 Measurement at 24±2 hours after test conclusion.	No visible damage ΔR ₂₅ /R ₂₅ ≤ 20%																																										
Moisture Resistance	MIL-STD-202 Method 106	Duration of 1 cycle: 24 hrs Number of cycles: 10, unpowered Measurement at 24±2 hours after test conclusion. <table border="1" style="margin-left: auto; margin-right: auto;"> <thead> <tr> <th rowspan="2">Step</th> <th colspan="2">Temp.(°C)</th> <th rowspan="2">Humidity (%)</th> <th rowspan="2">Period (hr)</th> </tr> <tr> <th>Start</th> <th>Finish</th> </tr> </thead> <tbody> <tr> <td>1</td> <td>25</td> <td>65</td> <td>90~100</td> <td>2.5</td> </tr> <tr> <td>2</td> <td>65</td> <td>65</td> <td>90~100</td> <td>3</td> </tr> <tr> <td>3</td> <td>65</td> <td>25</td> <td>80~100</td> <td>2.5</td> </tr> <tr> <td>4</td> <td>25</td> <td>65</td> <td>90~100</td> <td>2.5</td> </tr> <tr> <td>5</td> <td>65</td> <td>65</td> <td>90~100</td> <td>3</td> </tr> <tr> <td>6</td> <td>65</td> <td>25</td> <td>80~100</td> <td>2.5</td> </tr> <tr> <td>7</td> <td>25</td> <td>25</td> <td>80~100</td> <td>8</td> </tr> </tbody> </table>	Step	Temp.(°C)		Humidity (%)	Period (hr)	Start	Finish	1	25	65	90~100	2.5	2	65	65	90~100	3	3	65	25	80~100	2.5	4	25	65	90~100	2.5	5	65	65	90~100	3	6	65	25	80~100	2.5	7	25	25	80~100	8	No visible damage ΔR ₂₅ /R ₂₅ ≤ 20%
Step	Temp.(°C)			Humidity (%)	Period (hr)																																								
	Start	Finish																																											
1	25	65	90~100	2.5																																									
2	65	65	90~100	3																																									
3	65	25	80~100	2.5																																									
4	25	65	90~100	2.5																																									
5	65	65	90~100	3																																									
6	65	25	80~100	2.5																																									
7	25	25	80~100	8																																									
Biased Humidity	MIL-STD-202 Method 103	Test temp.: 85°C Rel. humidity of air: 85% Duration: 1000 hrs Bias at Max. Voltage V _{max} (V _{DC}) Measurement at 24±2 hours after test conclusion.	No visible damage ΔR ₂₅ /R ₂₅ ≤ 20%																																										
Operational Life	MIL-STD-202 Method 108	Test temp.: T _{max} . +3/-0°C Duration: 1000 hrs Bias at Max. Voltage V _{max} (V _{DC}) Measurement at 24±2 hours after test conclusion.	No visible damage ΔR ₂₅ /R ₂₅ ≤ 20%																																										
External Visual	MIL-STD-883 Method 2009	Inspect device construction, marking and workmanship.	No visible damage																																										
Physical Dimension	JESD22 Method JB-100	Verify physical dimensions to the applicable device specification.	Within the specified values																																										

PTC Thermistor for Automotive : TPM-C Series

SMD PTC Thermistor for Temperature Sensing



Item	Standard	Test Conditions / Methods	Specifications
Resistance to Solvents	MIL-STD-202 Method 215	Per MIL-STD-202 Method 215 Solvent: 1: 1 part (by volume) of isopropyl alcohol 3 part (by volume) of mineral spirits.	No visible damage
Mechanical Shock	MIL-STD-202-213	Test Condition F Peak value : 1500g's Half sine Waveform Normal duration (D) : 0.5ms In 3 directions perpendicularly intersecting each other (total 18 times).	No visible damage $ \Delta R_{25}/R_{25} \leq 20\%$
Vibration	MIL-STD-202 Method 204	Acceleration: 5 g's Sweep time: 20 min Frequency range: 10 to 2000 Hz 3x12 cycles	No visible damage $ \Delta R_{25}/R_{25} \leq 20\%$
Resistance to Soldering Heat	MIL-STD-202 Method 210	Condition B No pre-heat of samples. Temp. : 260±5°C, Time: 10±1s Immersion and emersion rate: 25mm/s ±6 mm/s Number of heat cycles: 1	No visible damage $ \Delta R_{25}/R_{25} \leq 20\%$
Thermal Shock	MIL-STD-202 Method 107	Lower test temp. : -40 +0/-3°C Upper test temp. : 125 +3/-0°C Maximum transfer time: 20 seconds. Dwell time: 15 minutes. Air-Air. Number of cycles: 300	No visible damage $ \Delta R_{25}/R_{25} \leq 20\%$
ESD	AEC-Q200-002	Discharge capacitance: 150 pF Charging voltage: 6 KV Contact discharge 1 pulse in each polarity	No visible damage $ \Delta R_{25}/R_{25} \leq 20\%$
Solderability	IEC 60068-2-58 J-STD-002	a) 4 hrs @ 155°C dry heat Dip @245±5°C 3±0.3sec b) Steam aging 8h±15min @93±3°C Dip @260±5°C 7±0.5sec	95% of termination wetted
Electrical Characterization	Specifications	Ta1:25±2°C Ta2:[Tsx + □°C] ±0.1°C Ta3:[Tsx - □°C] ±0.1°C	Within the specified values
Board Flex	AEC-Q200-005 (JIS-C-6429)	Bend the board: 2mm (Min.) Duration: 60 (+5) Sec	No visible damage $ \Delta R_{25}/R_{25} \leq 10\%$
Terminal Strength	AEC-Q200-006 (JIS-C-6429)	Apply force: 0.5kg (5 N) Duration of the applied forces: 60 (+1) Sec	No visible damage $ \Delta R_{25}/R_{25} \leq 20\%$

PTC Thermistor for Automotive : TPM-C Series

SMD PTC Thermistor for Temperature Sensing



■ Packaging

● Taping Specification

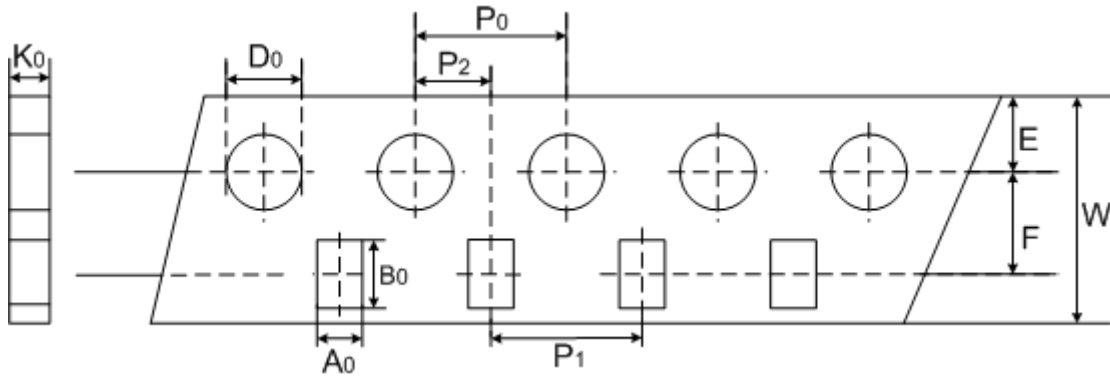

(Unit: mm)

Index	A ₀	B ₀	W	E	F	P ₁	P ₂	P ₀	D ₀	K ₀
Size	±0.2	±0.2	±0.2	±0.1	±0.05	±0.1	±0.05	±0.1	±0.1	±0.1
0603	1.1	1.9	8	1.75	3.5	4	2	4	1.55	0.95
0805	1.5	2.3	8	1.75	3.5	4	2	4	1.55	1.0

■ Quantity

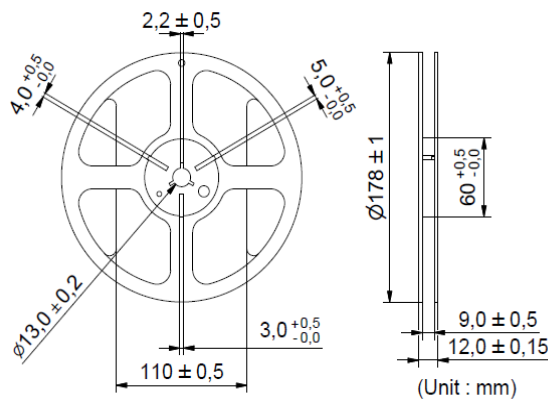

● 7" Reel

Type	Quantity (pcs/reel)
0603	4,000
0805	3,500

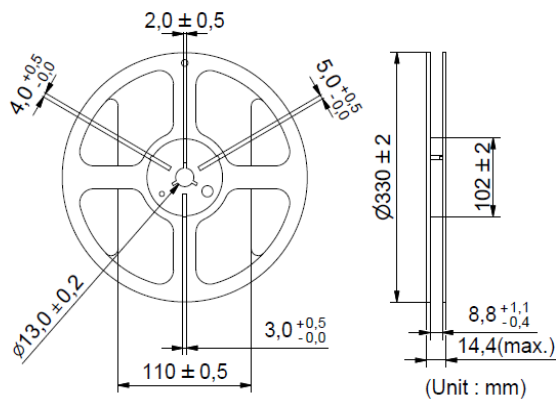

● 13" Reel

Type	Quantity (pcs/reel)
0603	16,000
0805	14,000

PTC Thermistor for Automotive : TPM-C Series

SMD PTC Thermistor for Temperature Sensing



■ Warehouse Storage Conditions of Products

- Storage Conditions :
 1. Storage Temperature: $-10^{\circ}\text{C} \sim +40^{\circ}\text{C}$
 2. Relative Humidity: $\leq 75\%RH$
 3. Keep away from corrosive atmosphere and sunlight.
- Period of Storage : 1 year