

ESD Protection Diode : TEUST26050R8U

SOT23-6 package ultra-low capacitance type



■ Features

1. RoHS compliant and halogen-free
2. Working voltage: 5V
3. Ultra-low capacitance: 0.8pF
4. Low clamping voltage
5. Low leakage current
6. IEC 61000-4-2 (ESD) ±15KV (air), ±8KV (contact)



■ Recommended Applications

1. USB 1.1/2.0/OTG
2. 10/100/1000 Ethernet
3. Projection TV Monitors and Flat Panel Displays
4. Digital Visual Interface (DVI)

■ Mechanical Data

1. Case: SOT23-6, molded plastic meets UL flammability rating 94V-0
2. Terminals : Au plated, solderable per MIL-STD-750, method 2026
3. Meets MSL level 1, per J-STD-020

■ Part Number Code

T	E	D	S	T	2	6	0	5	0	R	8	U
1	2	3	4	5	6	7	8	9	10	11	12	13

Product Series		Type code		Package		Reverse Stand off Voltage(V_{RWM})		Junction Capacitance(C_j)		Type Code	
TE	THINKING ESD Transient Voltage Suppression Diodes	D	Standard Capacitance >10pF	SD32	SOD-323, 2pins	05	5V	0R8	0.8pF	U	Uni-directional
		L	Low Capacitance >1pF, ≤10pF	D102	DFN1006, 2pins			030	3.0pF	B	Bi-directional,
		U	Ultra-low Capacitance ≤1pF	D062	DFN0603, 2pins			03D	3.3pF		
								280	28pF		

ESD Protection Diode : TEUST26050R8U

SOT23-6 package ultra-low capacitance type



Structures and Dimensions

SOT-23-6

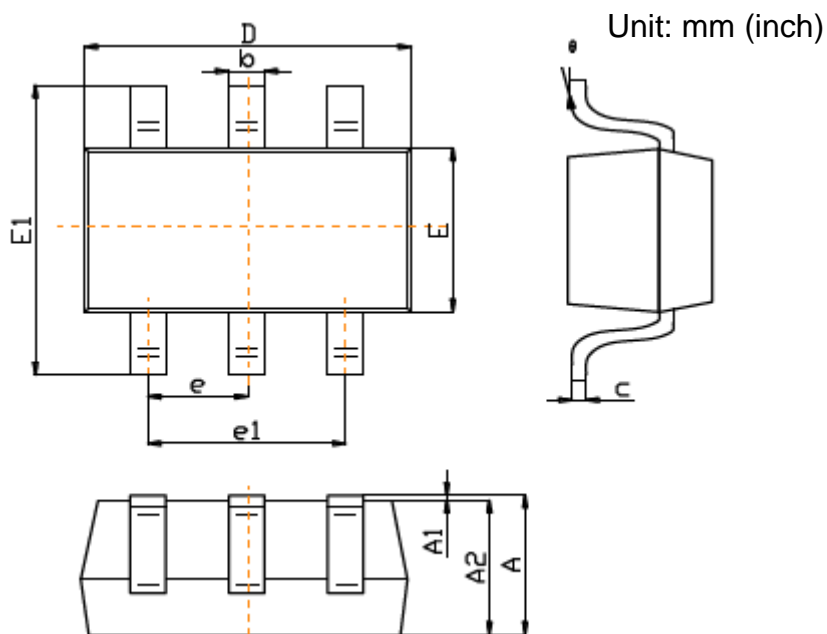

Code	Unit: mm		Unit: inch	
	Min.	Max.	Min.	Max.
A	1.050	1.250	0.041	0.049
A1	0.000	0.100	0.000	0.004
A2	1.050	1.150	0.041	0.045
b	0.300	0.500	0.012	0.020
c	0.100	0.200	0.004	0.008
D	2.820	3.020	0.111	0.119
E	1.500	1.700	0.059	0.067
E1	2.650	2.950	0.104	0.116
e	0.950BSC		0.037 BSC	
e1	1.800	2.000	0.071	0.079
L	0.300	0.600	0.012	0.024
θ	0	8°	0	8°

ESD Protection Diode : TEUST26050R8U

SOT23-6 package ultra-low capacitance type



■ Schematic & PIN Configuration

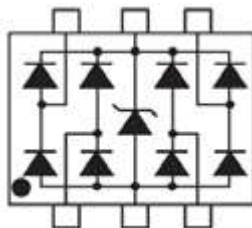

■ Maximum Rating (Rating at 25°C ambient temperature unless otherwise noted)

Parameter	Symbol	Value	Unit
Peak pulse power (tp= 8/20μs waveform)	P _{PPM}	50	W
Peak pulse current (tp= 8/20μs waveform)	I _{PP}	4	A
ESD per IEC61000-4-2 (Air) ESD per IEC61000-4-2 (Contact)	V _{ESD}	±15 ±8	KV
Operating junction temperature	T _J	-55~+125	°C
Storage temperature range	T _{STG}	-55~+150	°C

■ Electrical Characteristics (T_A=25°C unless otherwise noted)

Parameter	Symbol	Condition	Min.	Typ.	Max.	Unit
Reverse Stand-off Voltage	V _{RWM}	-			5	V
Breakdown Voltage	V _{BR}	I _T =1mA	6			V
Reverse Leakage Current	I _R	V _{RWM} =5V			1.0	μA
Clamping Voltage	V _c	I _{pp} =1A, tp= 8/20μs I _{pp} =3A, tp= 8/20μs			9 11	V
Junction Capacitance	C _j	V _R =0V, f=1MHz, Between I/O pins V _R = 0V, f = 1MHz Any I/O pin to Ground		0.35 0.8	0.45 1.0	pF

ESD Protection Diode : TEUST26050R8U

SOT23-6 package ultra-low capacitance type



■ Rate and Characteristic Curve ($T_A=25^\circ\text{C}$ unless otherwise noted)

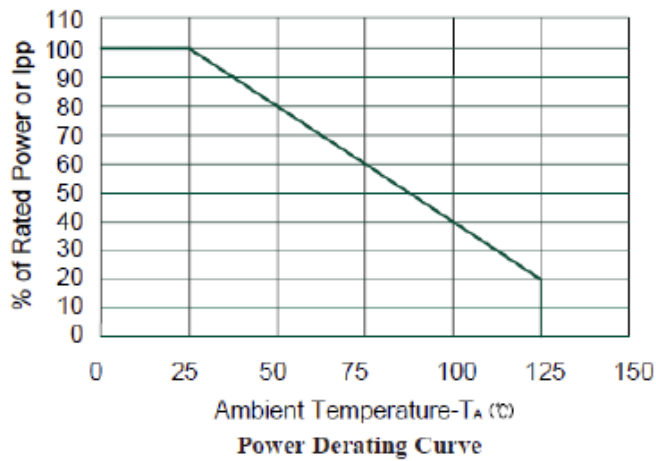
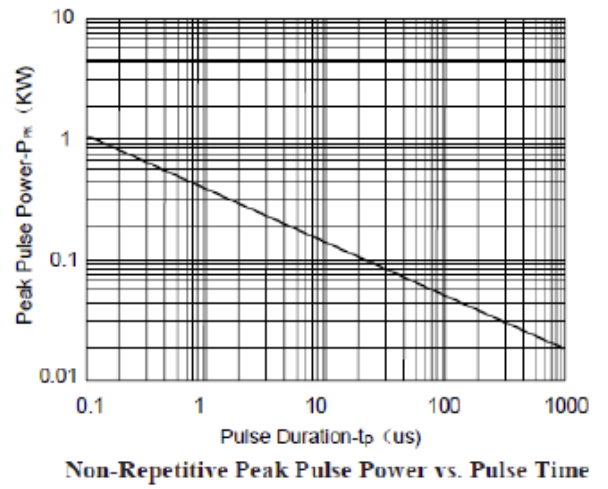
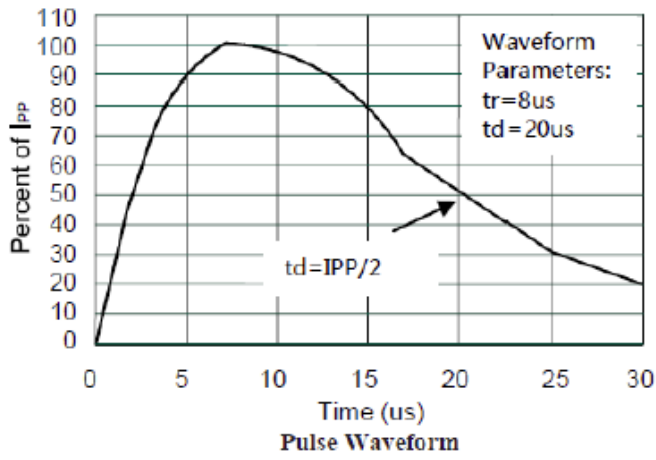

ESD Protection Diode : TEUST26050R8U

SOT23-6 package ultra-low capacitance type



■ Soldering Recommendation

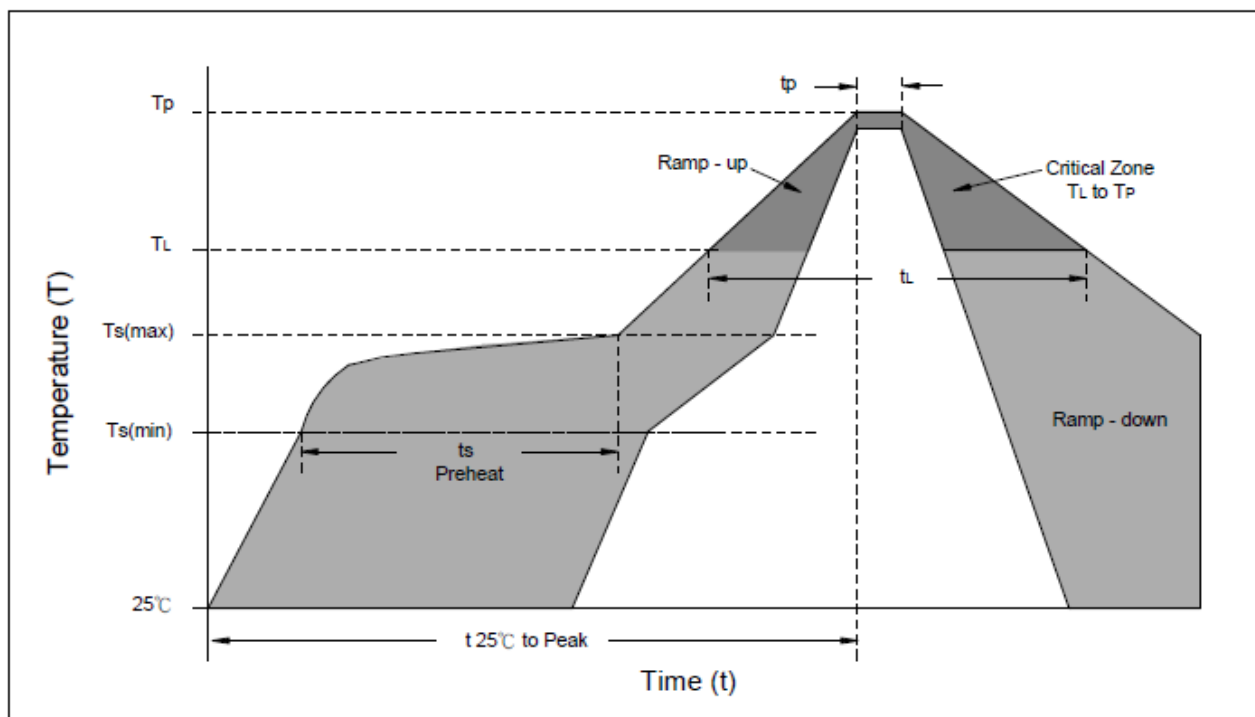

Reflow Condition	Lead-free assembly
Preheat -Temperature Min(Ts min) -Temperature Min(Ts max) -Time (min to max) (ts)	150°C 200°C 60 – 180 seconds
Average ramp up rate -Temperature Liquidus (TL) to peak	3°C/second max
Ts(max) to TL -Ramp-up Rate	3°C/second max.
Reflow -Temperature Liquidus (TL) -Time (tL)	217°C 60 – 150 seconds
Peak Temperature (TP)	260°C
Time within 5°C of actual peak Temperature(TP)	20 – 40 seconds
Ramp-down Rate	6°C/second max.
Time 25°C to peak Temperature(TP)	8 minutes max.
Do not exceed	260°C

ESD Protection Diode : TEUST26050R8U

SOT23-6 package ultra-low capacitance type



Recommended Soldering Pad Dimensions

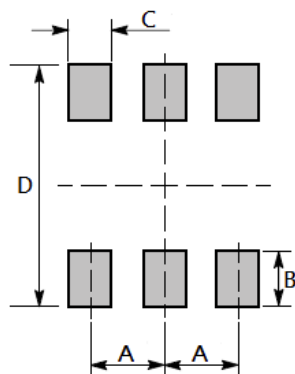

Unit: mm

Package Type	A	B	C	D
SOT-23-6	0.95	1.00	0.70	3.40

Packaging

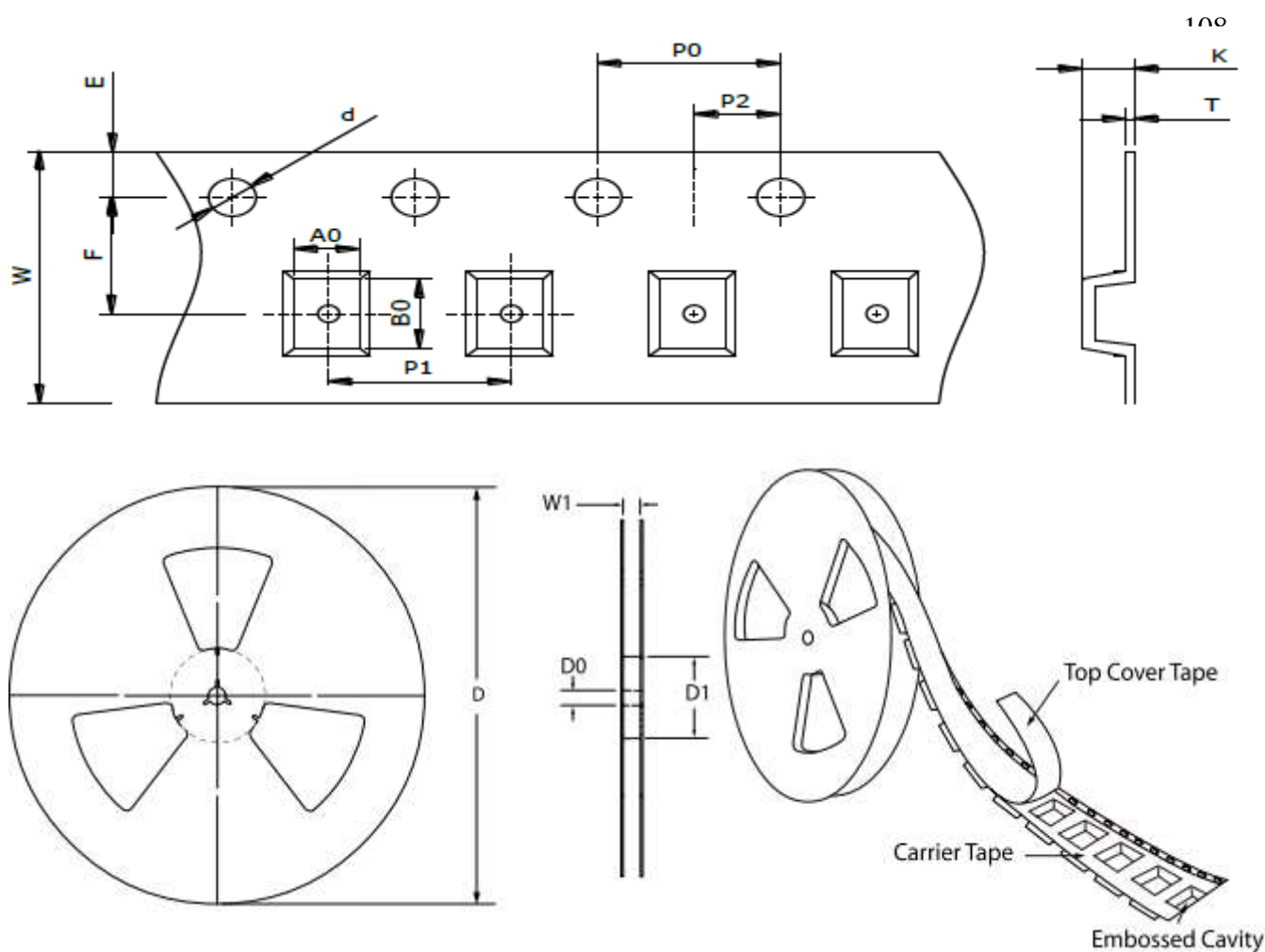

ESD Protection Diode : TEUST26050R8U

SOT23-6 package ultra-low capacitance type



Item	Symbol	SOT-23-6 (Unit: mm)
Carrier width	A0	3.10 ± 0.10
Carrier length	B0	3.20 ± 0.10
Carrier length	K	1.10± 0.10
Sprocket hole	d	1.50 ± 0.10
Reel outside diameter	D	178.00 ± 2.00
Feed hole width	D0	13.00 ± 0.20
Reel inner diameter	D1	MIN. 54.00
Sprocke hole position	E	1.75 ± 0.10
Punch hole position	F	3.50 ± 0.10
Sprocke hole pitch	P0	4.00 ± 0.10
Punch hole pitch	P1	4.00 ± 0.10
Embossment center	P2	2.00 ± 0.10
Overall tape thickness	T	0.20 ± 0.05
Tape width	W	8.00 ± 0.20
Reel width	W1	MAX. 13.50

■ Quantity

Package Type	Marking Code	Reel Size (inch)	Reel (Kpcs)
SOT-23-6	.V05	7	3

■ Warehouse Storage Conditions of product

- Storage condition:
 - 1.Storage Temperature: -10℃~+40℃
 - 2.Relative Humidity: ≤75%RH
 - 3.Keep away from corrosive atmosphere and sunlight.
- Period of Storage: 1 year.