

■ Thermistor

A thermistor is a thermally sensitive semiconductor resistor, and its resistance changes following the change of temperature.

■ Negative Temperature Coefficient Thermistor (NTC Thermistor)

NTC thermistor is a resistor whose resistance decreases following the increase of temperature.

■ Zero-Power Resistance (R_T)

The zero-power resistance is the resistance value measured under specified temperature conditions, and the self-heating during measurement can be negligible or the change of resistance caused by self-heating during measurement is less than 0.1%.

■ Rated Zero-Power Resistance (R_{25})

The rated zero-power resistance is the nominal value at standard temperature of 25°C.

■ B-Value

The B-value is an index of thermal sensitivity and represents slope of R/T curves. It can be showed by the formula below,

$$B = \frac{T_1 \cdot T_2}{T_2 - T_1} \cdot \text{Log}_e \frac{R_1}{R_2}$$

Or

$$B = 2.303 \frac{T_1 \cdot T_2}{T_2 - T_1} \cdot \text{Log}_{10} \frac{R_1}{R_2}$$

Note:

B: absolute temperature in Kelvins (K)

R_1 : resistance in ohms (Ω) at temperature T_1

R_2 : resistance in ohms (Ω) at temperature T_2

$T_1=298.15\text{K}$ (+25°C), $T_2=358.15\text{K}$ (+85°C) for B25/85

$T_1=298.15\text{K}$ (+25°C), $T_2=323.15\text{K}$ (+50°C) for B25/50

■ Operating Temperature Range

The operating temperature range is ambient temperature range for thermistor's continuous operation at zero-power.

Limits of the upper and lower operating temperatures are specified in each series.

■ Maximum Rated Power Dissipation (Pmax)

The maximum rated power dissipation is the maximum power rating applied to the thermistor continuously at 25°C. Please refer to derating curve below when the ambient temperature is over 25°C or below 0°C. The curve is derated linearly to 0% at T_L and T_U.

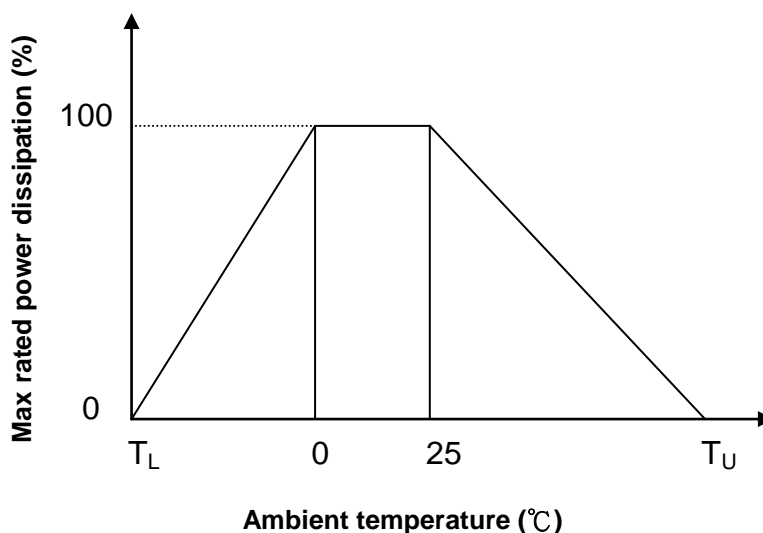

■ Dissipation Factor (δ)

Dissipation factor is ratio of thermistor's temperature change caused by its dissipation power under specific ambient temperature. It can be expressed by the formula below,

$$\delta = P / (T_2 - T_1)$$

It is expressed in mW/°C which stands for dissipation power for thermistor's increase of 1°C.

■ Thermal Time Constant (τ)

The thermal time constant is a 63.2% change of thermistor's body temperature from its initial temperature (T₀) to specific temperature (T₁) under zero-power conditions.

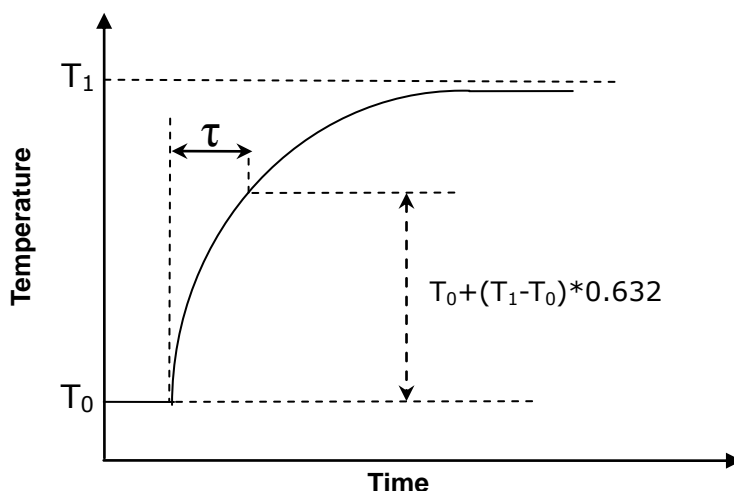

• Table 1: Thermal time constant and temperature change ratio.

| Code | Rate of change (%) for $T_0 \sim T_1$ |
|---------|---------------------------------------|
| τ | 63.2 |
| 2τ | 86.5 |
| 3τ | 95.0 |
| 4τ | 98.2 |
| 5τ | 99.4 |
| 6τ | 99.8 |
| 7τ | 99.9 |

■ Recommend Capacitance (For SCK series only)

The recommend capacitance is the maximum allowable capacitance of SCK in power supply applications. SCK recommends capacitance value should be higher than capacitance value of filter capacitor that is part of back-end circuit of bridge rectifier.

■ Resistance/Temperature Characteristic (RT Characteristic)

RT characteristic is the relationship between zero-power resistance and body temperature of a thermistor. The resistance law follows approximately the formula below:

$$R = R_1 e^{B \left(\frac{1}{T} - \frac{1}{T_1} \right)}$$

R and R_1 are the values of a thermistor's zero-power resistance measured at temperature T and T_1 respectively. The temperatures are expressed in absolute temperature (in Kelvins), and B is the thermal sensitivity index.

■ Voltage/Current Characteristic (VI Characteristic)

VI characteristic is the relationship between dc or ac voltages across the thermistor and the applied steady-state current under 25°C still air.

NTC Thermistor : Application



■ Temperature Measurement

NTC thermistor is a practical and low-cost solution to most temperature measurement applications. One of the circuits for temperature measurement is Wheatstone bridge with NTC thermistor as a bridge leg.

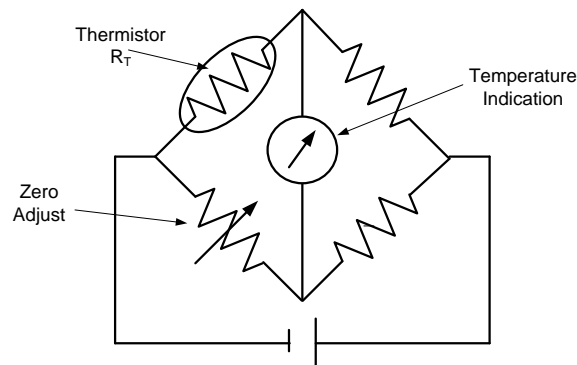

■ Temperature Control

NTC thermistor is a popular and simple solution for temperature control systems. The circuit below is control circuit that consists of thermistor and voltage comparator. The circuit converts temperature to comparator output voltage, and the voltage controls other switch components (such as transistor) to offer temperature control or over-temperature protection.

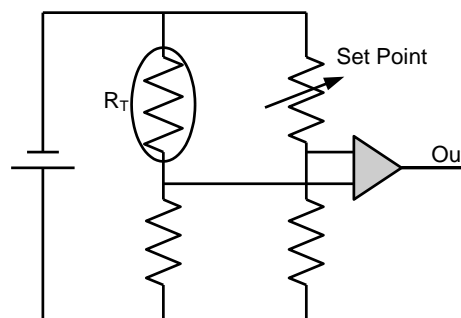

■ Temperature Compensation

Many semiconductors and ICs exhibit a positive temperature coefficient, which may cause some problems, such as poor accuracy. NTC thermistor with negative temperature coefficient offers temperature compensation and makes those devices to produce stable performance over a wide temperature range. The circuit below is a case of temperature compensation. Thermistor (R_T) and linear resistor (R_p) are connected in parallel, and then are connected in series with components with positive temperature coefficient (R_s). After compensation, the resistance becomes more stable in a wide operating temperature range.

