

Metal Oxide Varistor : TVR-V Series



Disc Type Varistor for Surge Protection (Medium Surge Series)

■ Features

1. RoHS compliant
2. Halogen-free series are available
3. Body size: $\Phi 10$ and $\Phi 14$ mm
4. Wide operating voltage range: 130Vac ~ 680Vac
5. Operating temperature range: $-40^{\circ}\text{C} \sim +105^{\circ}\text{C}$
Storage temperature range : $-40^{\circ}\text{C} \sim +125^{\circ}\text{C}$
6. Agency recognition: UL 1449 4th / cUL / TUV/ VDE/ CQC

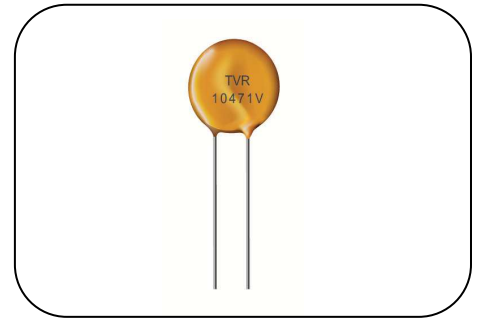

Note: V of the marking stands for TVR-V series

■ Recommended Applications

1. Power supply
2. Home appliance
3. Industrial equipment
4. Telecommunication or telephone system
5. Smart meter
6. PLC (Power line communication)
7. Lighting products
8. Photovoltaic industry

■ Part Number Code

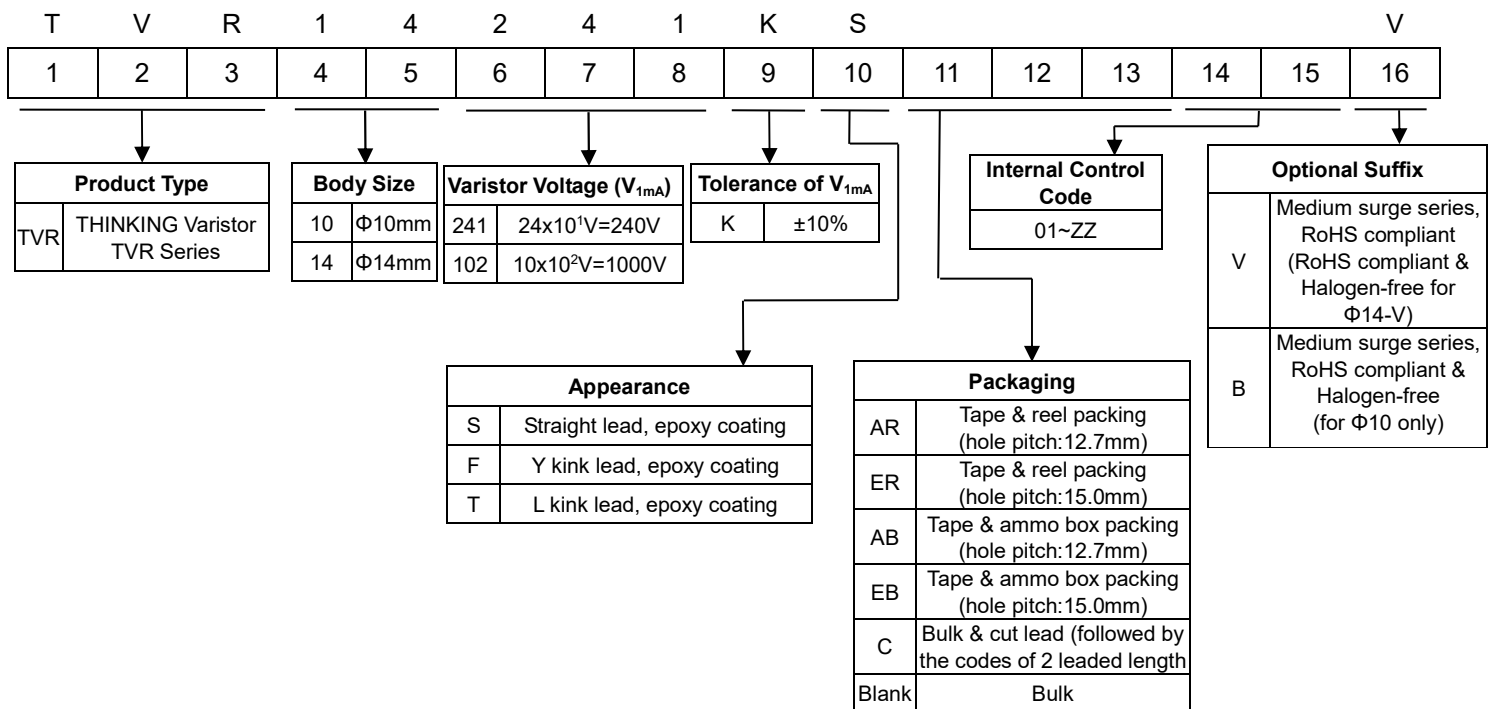

Note: Optional suffix will be the 11th digit if packaging and internal control codes are not coded.

Metal Oxide Varistor : TVR-V Series



Disc Type Varistor for Surge Protection (Medium Surge Series)

■ Structure and Dimensions

■ S Type (Straight lead)

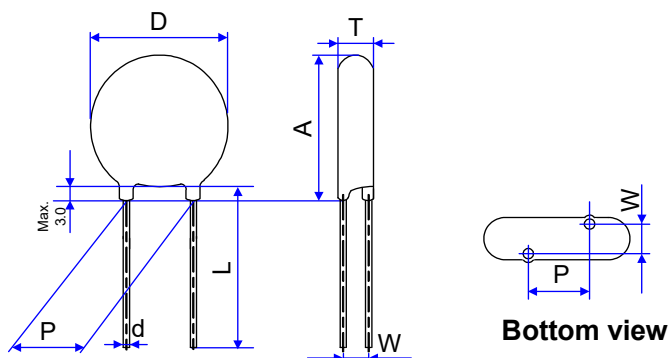

(Unit: mm)

Series	D	L _{min.}	d	P	A _{max.}	T _{max.}	W
TVR10-V	9.5~12.5	26.5	0.8±0.02	7.5±0.5 (for TVR10201-561-V) 7.5±1.0 (for TVR10621-112-V)	15.0	Please refer to Electrical Characteristics Table	
TVR14-V	13.5~16.0	26.5	0.8±0.02	7.5±0.5 (for TVR14201-561-V) 7.5±1.0 (for TVR14621-112-V)	18.5 (for TVR14201-511-V) 19.0 (for TVR14561-112-V)		

■ F Type (Y kink lead)

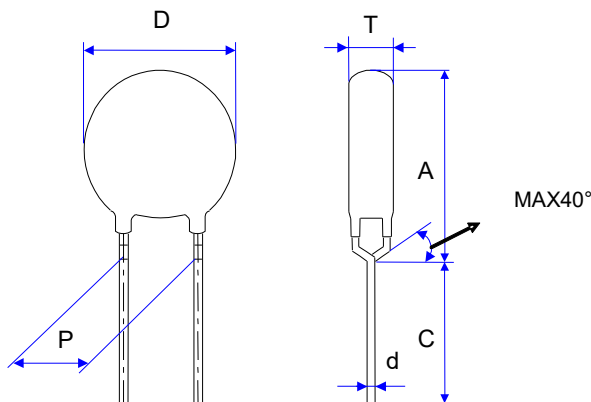

(Unit: mm)

Series	D	C _{min.}	d	P	A _{max.}	T _{max.}
TVR10-V	9.5~12.5	20	0.8±0.02	7.5±0.5 (for TVR10201-561-V) 7.5±1.0 (for TVR10621-112-V)	16.0	Please refer to Electrical Characteristics Table
TVR14-V	13.5 ~16.0	20	0.8±0.02	7.5±0.5 (for TVR14201-561-V) 7.5±1.0 (for TVR14621-112-V)	19.0	

Metal Oxide Varistor : TVR-V Series



Disc Type Varistor for Surge Protection (Medium Surge Series)

■ T Type (L kink lead)

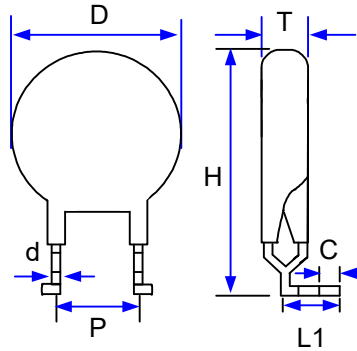

(Unit: mm)

Series	D	Cmin.	d	P	Hmax.	L1	Tmax.
TVR10-V	9.5~12.5	3.8±0.8	0.8±0.02	7.5±1	20.0	7.0±1	Please refer to Electrical Characteristics Table
TVR14-V	13.5 ~16.0			7.5±1	23.5	10.0±1	

Metal Oxide Varistor : TVR-V Series



Disc Type Varistor for Surge Protection (Medium Surge Series)

■ Electrical Characteristics

10-V Series

Part No.	Varistor Voltage (@ 1mA DC)	Max. Continuous Voltage		Max. Clamping Voltage (8/20 μ s)		Max. Surge Current (8/20 μ s)	Rated Power	Max. Energy (10/1000 μ s)	Dimension		
	V _{1mA}	V _{AC(rms)}	V _{DC}	V _P	I _P	I _{max}	P	W _{max}	T _{min}	T _{max}	W \pm 1.0
	(V)	(V)	(V)	(V)	(A)	(A)	(W)	(J)	(mm)		
TVR10201-V	200 (180~220)	130	170	340	25	3500	0.4	35	2.9	4.4	1.7
TVR10221-V	220 (198~242)	140	180	360	25	3500	0.4	39	3.0	4.5	1.7
TVR10241-V	240 (216~264)	150	200	395	25	3500	0.4	42	3.1	4.6	1.8
TVR10271-V	270 (243~297)	175	225	455	25	3500	0.4	49	3.3	5.0	1.9
TVR10301-V	300 (270~330)	195	250	500	25	3500	0.4	53	3.5	5.3	2.1
TVR10331-V	330 (297~363)	215	275	550	25	3500	0.4	58	3.8	5.7	2.2
TVR10361-V	360 (324~396)	230	300	595	25	3500	0.4	65	4.0	6.0	2.3
TVR10391-V	390 (351~429)	250	320	650	25	3500	0.4	70	4.2	6.2	2.5
TVR10431-V	430 (387~473)	275	350	710	25	3500	0.4	80	4.3	6.5	2.5
TVR10471-V	470 (423~517)	300	385	775	25	3500	0.4	85	4.4	6.6	2.6
TVR10511-V	510 (459~561)	320	410	845	25	3500	0.4	92	4.6	6.8	2.8
TVR10561-V	560 (504~616)	350	450	930	25	3500	0.4	92	4.7	7.1	3.0
TVR10621-V	620 (558~682)	395	510	1020	25	3500	0.4	95	4.8	7.2	3.2
TVR10681-V	680 (612~748)	420	560	1120	25	3500	0.4	98	4.9	7.4	3.4
TVR10751-V	750 (675~825)	465	615	1235	25	3500	0.4	100	5.1	7.6	3.7
TVR10781-V	780 (702~858)	485	640	1300	25	3500	0.4	104	5.1	7.7	3.8
TVR10821-V	820 (738~902)	510	670	1355	25	3500	0.4	110	5.2	7.8	3.4
TVR10911-V	910 (819~1001)	550	745	1500	25	3500	0.4	130	5.3	8.0	3.7
TVR10102-V	1000 (900~1100)	625	825	1650	25	3500	0.4	140	5.3	8.3	4.0
TVR10112-V	1100 (990~1210)	680	895	1815	25	3500	0.4	155	5.7	8.6	4.3

Metal Oxide Varistor : TVR-V Series



Disc Type Varistor for Surge Protection (Medium Surge Series)

14-V Series





Part No.	Varistor Voltage (@ 1mA DC)	Max. Continuous Voltage		Max. Clamping Voltage (8/20 μ s)		Max. Surge Current (8/20 μ s)	Rated Power	Max. Energy (10/1000 μ s)	Dimension		
	V _{1mA}	V _{AC(rms)}	V _{DC}	V _P	I _P	I _{max}	P	W _{max}	T _{min}	T _{max}	W \pm 1.0
	(V)	(V)	(V)	(V)	(A)	(A)	(W)	(J)	(mm)		
TVR14201-V	200 (180~220)	130	170	340	50	6000	0.6	84	2.9	4.4	1.7
TVR14221-V	220 (198~242)	140	180	360	50	6000	0.6	91	3.0	4.5	1.7
TVR14241-V	240 (216~264)	150	200	395	50	6000	0.6	98	3.1	4.7	1.8
TVR14271-V	270 (243~297)	175	225	455	50	6000	0.6	112	3.3	4.9	1.9
TVR14301-V	300 (270~330)	195	250	500	50	6000	0.6	123	3.4	5.1	2.1
TVR14331-V	330 (297~363)	215	275	550	50	6000	0.6	133	3.5	5.3	2.2
TVR14361-V	360 (324~396)	230	300	595	50	6000	0.6	147	3.6	5.5	2.3
TVR14391-V	390 (351~429)	250	320	650	50	6000	0.6	161	3.7	5.6	2.5
TVR14431-V	430 (387~473)	275	350	710	50	6000	0.6	182	3.8	5.7	2.5
TVR14471-V	470 (423~517)	300	385	775	50	6000	0.6	196	3.9	5.9	2.6
TVR14511-V	510 (459~561)	320	420	845	50	6000	0.6	210	4.1	6.1	2.8
TVR14561-V	560 (504~616)	350	460	930	50	6000	0.6	231	4.2	6.4	3.0
TVR14621-V	620 (558~682)	395	510	1020	50	6000	0.6	252	4.5	6.7	3.2
TVR14681-V	680 (612~748)	420	560	1120	50	6000	0.6	266	4.7	7.1	3.4
TVR14751-V	750 (675~825)	465	615	1235	50	6000	0.6	280	5.0	7.5	3.7
TVR14781-V	780 (702~858)	485	640	1300	50	6000	0.6	280	5.1	7.7	3.8
TVR14821-V	820 (738~902)	510	670	1355	50	6000	0.6	280	5.2	7.9	3.4
TVR14911-V	910 (819~1001)	550	745	1500	50	6000	0.6	308	5.6	8.4	3.7
TVR14102-V	1000 (900~1100)	625	825	1650	50	6000	0.6	336	5.9	8.9	4.0
TVR14112-V	1100 (990~1210)	680	895	1815	50	6000	0.6	336	6.3	9.5	4.3

Metal Oxide Varistor : TVR-V Series



Disc Type Varistor for Surge Protection (Medium Surge Series)

■ Safety Approvals

Certified Model No.	Agency						
							
	UL1449 5 th & cUL	EN/IEC 61051-1, IEC 61051-2, IEC 61051-2-2	IEC62368-1 Annex G.8.1	DIN/ EN/ IEC 61051-1 DIN/ EN/ IEC 61051-2 IEC 61051-2-2	IEC62368-1 Annex G.8.1	GB/T10193-1997 GB/T10194-1997	GB8898-2011 GB4943.1-2011
	E314979	J50411758		5944		CQC10001041748 CQC10001041749	
TVR10201-V	√	√	√	√	√	√	
TVR10221-V	√	√	√	√	√	√	
TVR10241-V	√	√	√	√	√	√	
TVR10271-V	√	√	√	√	√	√	
TVR10301-V	√	√	√	√	√	√	
TVR10331-V	√	√	√	√	√	√	
TVR10361-V	√	√	√	√	√	√	
TVR10391-V	√	√	√	√	√	√	
TVR10431-V	√	√	√	√	√	√	√
TVR10471-V	√	√	√	√	√	√	√
TVR10511-V	√	√	√	√	√	√	√
TVR10561-V	√	√	√	√	√	√	√
TVR10621-V	√	√	√	√	√	√	√
TVR10681-V	√	√	√	√	√	√	√
TVR10751-V	√	√	√	√	√	√	√
TVR10781-V	√						
TVR10821-V	√	√	√	√	√	√	√
TVR10911-V	√	√	√	√	√	√	√
TVR10102-V	√	√	√	√	√	√	√
TVR10112-V	√	√	√	√	√	√	√

Metal Oxide Varistor : TVR-V Series



Disc Type Varistor for Surge Protection (Medium Surge Series)

Certified Model No.	Agency						
	UL1449 5 th & cUL	EN/IEC 61051-1, IEC 61051-2, IEC 61051-2-2	IEC62368-1 Annex G.8.1	DIN/ EN/ IEC 61051-1 DIN/ EN/ IEC 61051-2 IEC 61051-2-2	IEC62368-1 Annex G.8.1	GB/T10193-1997 GB/T10194-1997	GB8898-2011 GB4943.1-2011
	E314979	J50411758		5944		CQC13001089859 CQC13001089857	
TVR14201-V	√	√	√	√	√	√	
TVR14221-V	√	√	√	√	√	√	
TVR14241-V	√	√	√	√	√	√	
TVR14271-V	√	√	√	√	√	√	
TVR14301-V	√	√	√	√	√	√	
TVR14331-V	√	√	√	√	√	√	
TVR14361-V	√	√	√	√	√	√	
TVR14391-V	√	√	√	√	√	√	
TVR14431-V	√	√	√	√	√	√	√
TVR14471-V	√	√	√	√	√	√	√
TVR14511-V	√	√	√	√	√	√	√
TVR14561-V	√	√	√	√	√	√	√
TVR14621-V	√	√	√	√	√	√	√
TVR14681-V	√	√	√	√	√	√	√
TVR14751-V	√	√	√	√	√	√	√
TVR14751-V	√						
TVR14821-V	√	√	√	√	√	√	√
TVR14911-V	√	√	√	√	√	√	√
TVR14102-V	√	√	√	√	√	√	√
TVR14112-V	√	√	√	√	√	√	√

Metal Oxide Varistor : TVR-V Series



Disc Type Varistor for Surge Protection (Medium Surge Series)

Power Derating Curve

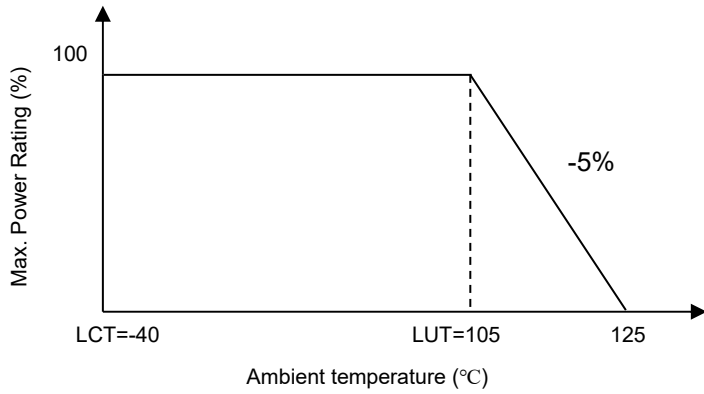

Surge Current Standard Waveform

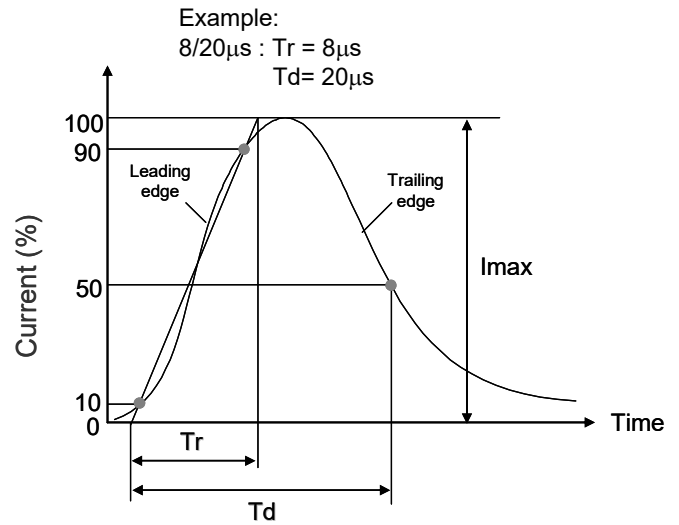

Max. Surge Current Derating Curves

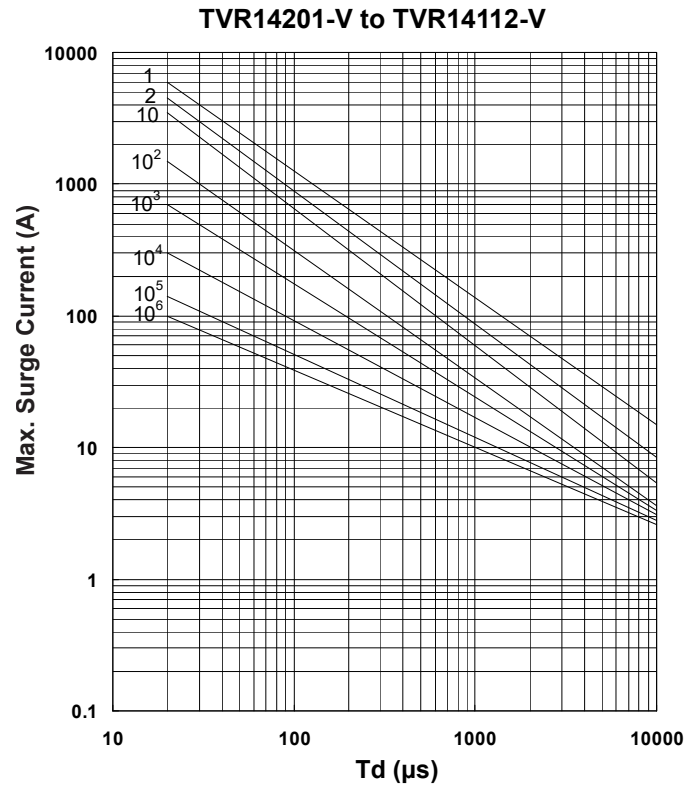
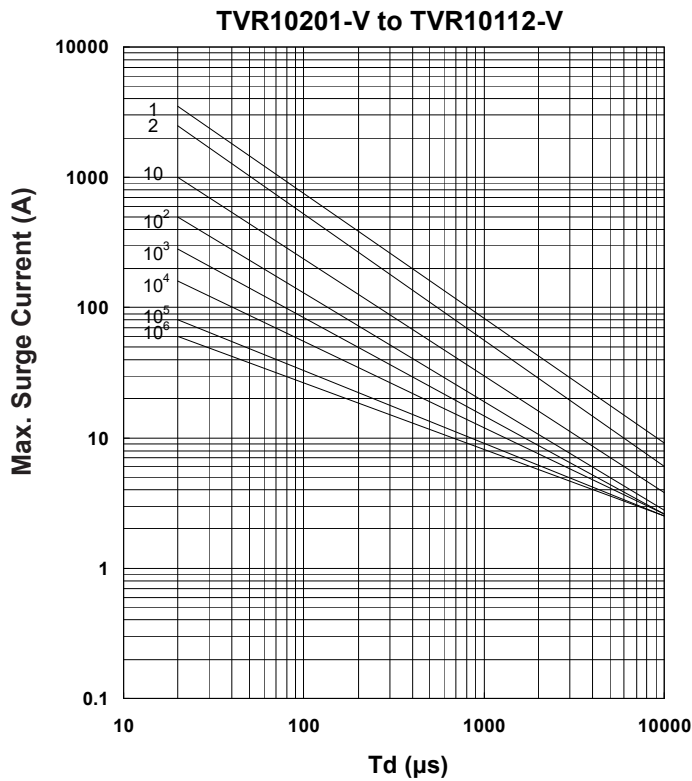

Metal Oxide Varistor : TVR-V Series



Disc Type Varistor for Surge Protection (Medium Surge Series)

■ Max. Leakage Current and Max. Clamping Voltage Curves

Max. Leakage Current and Max. Clamping Voltage Curves (TVR10201-V to TVR10621-V)

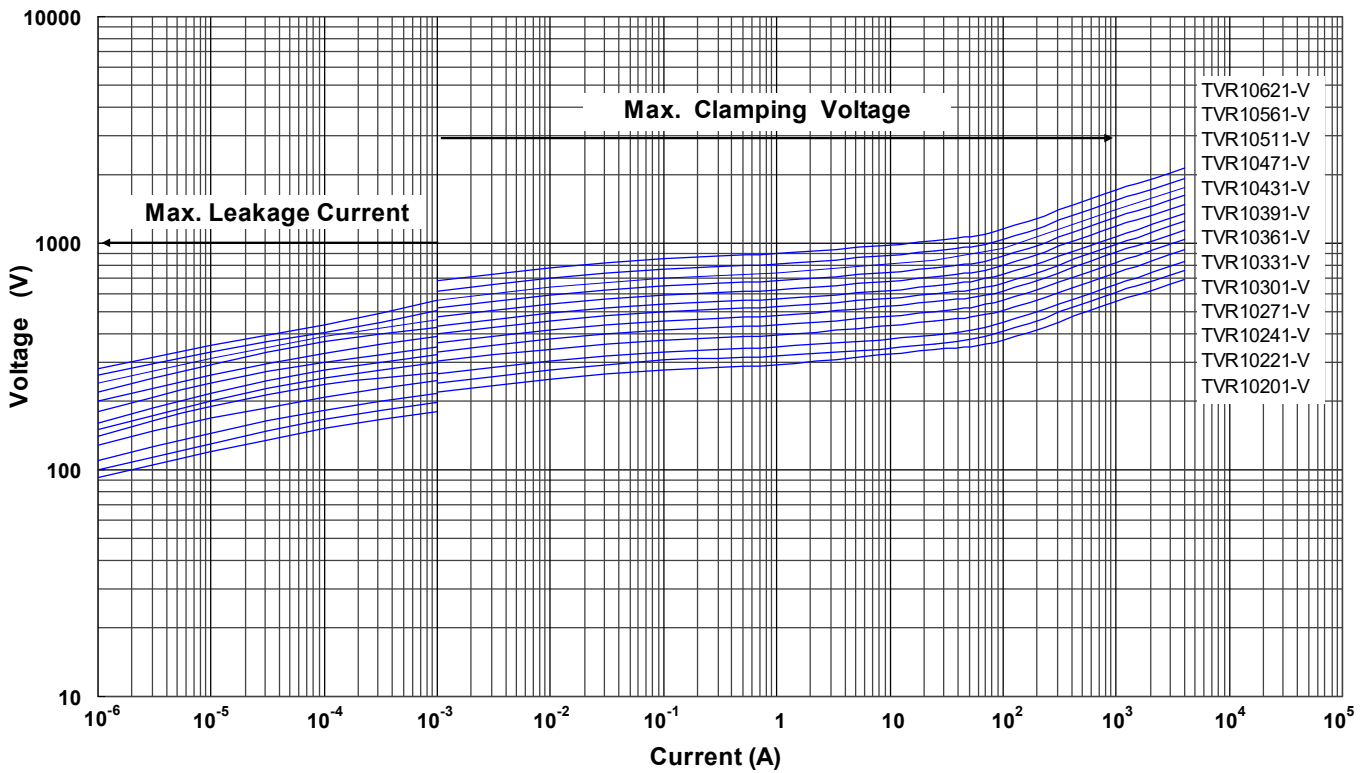

Max. Leakage Current and Max. Clamping Voltage Curves (TVR10681-V to TVR10112-V)

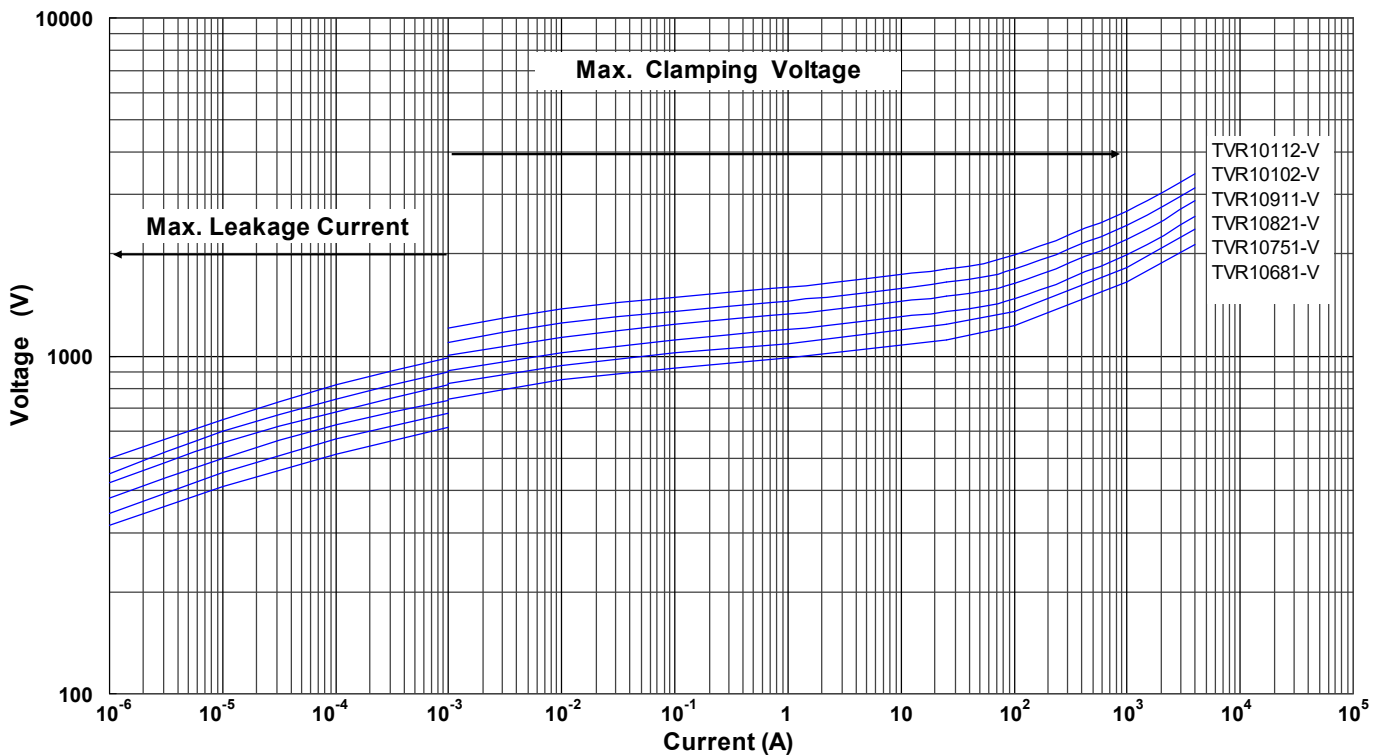

Metal Oxide Varistor : TVR-V Series



Disc Type Varistor for Surge Protection (Medium Surge Series)

■ Max. Leakage Current and Max. Clamping Voltage Curves

Max. Leakage Current and Max. Clamping Voltage Curves (TVR14201-V to TVR14471-V)

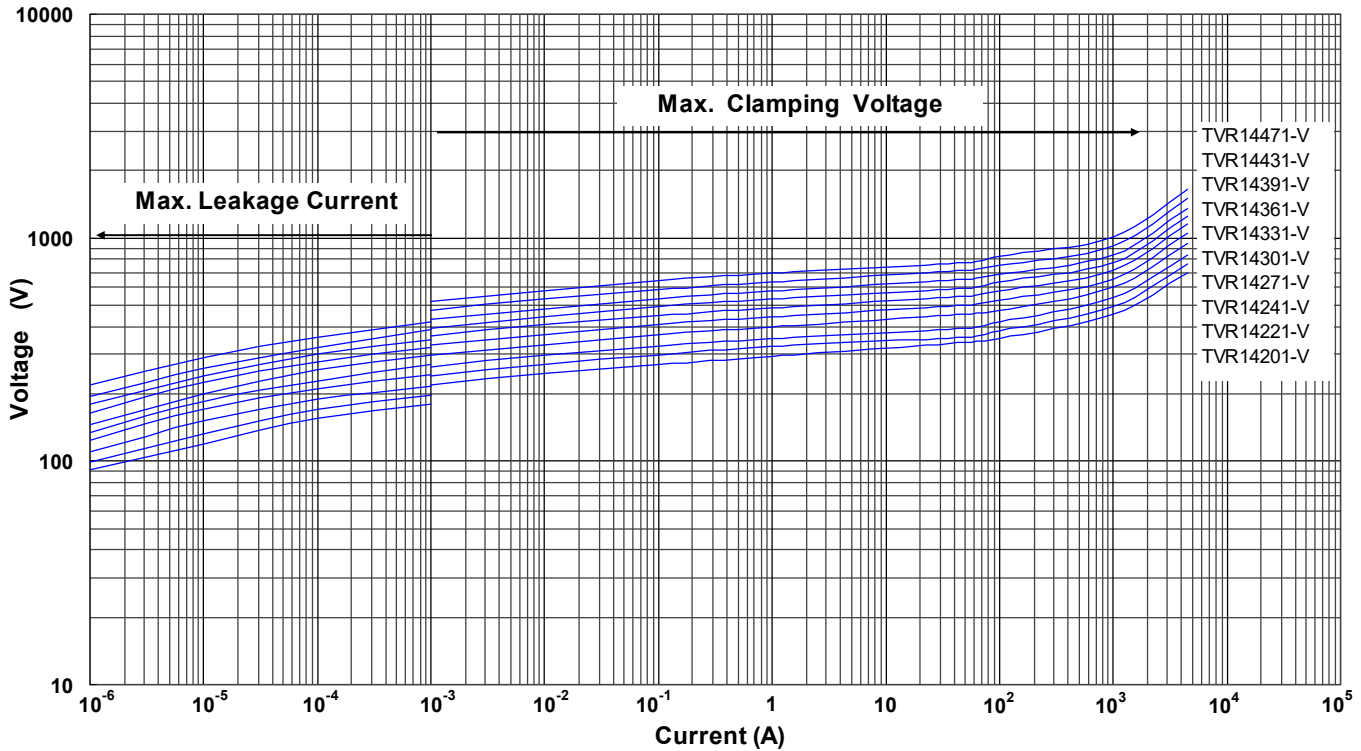

Max. Leakage Current and Max. Clamping Voltage Curves (TVR14511-V to TVR14112-V)

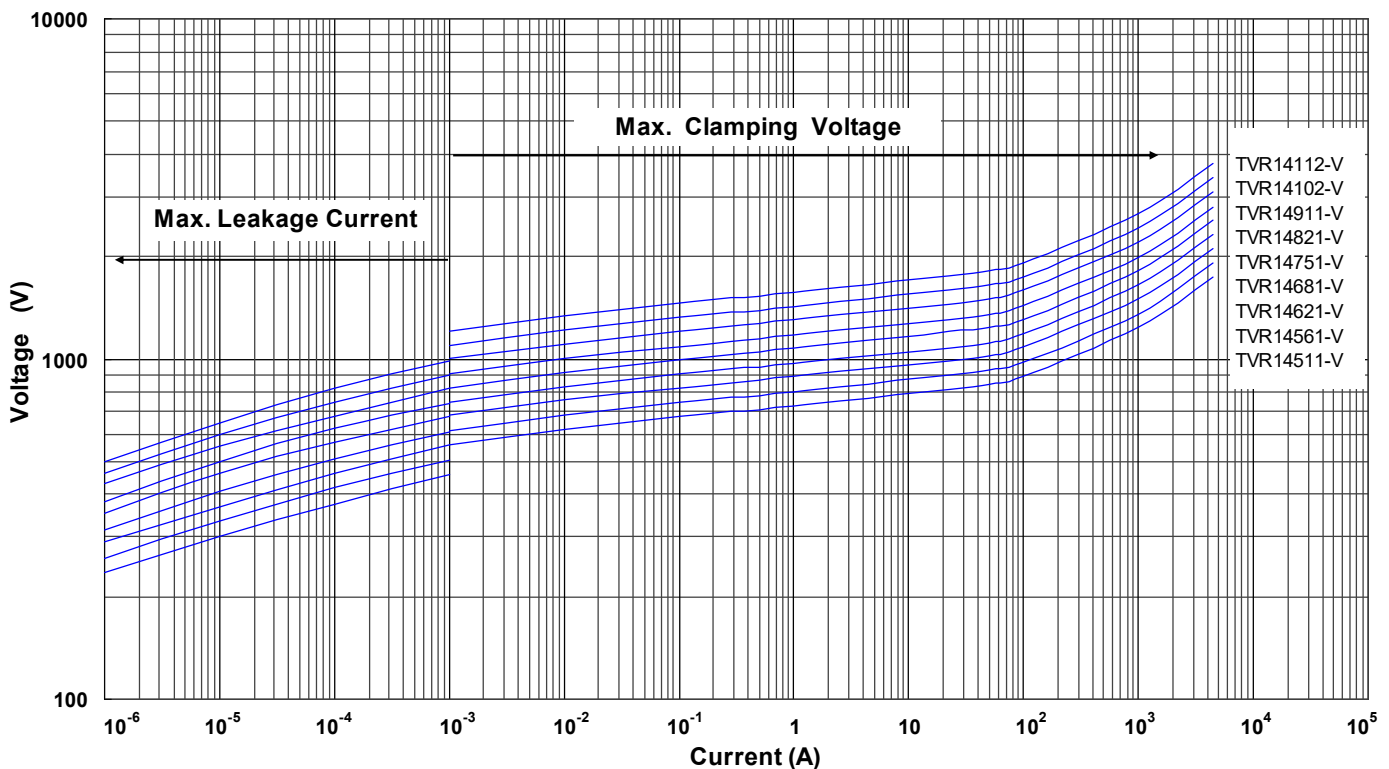

Metal Oxide Varistor : TVR-V Series



Disc Type Varistor for Surge Protection (Medium Surge Series)

■ Soldering Recommendation

● Wave Soldering Profile

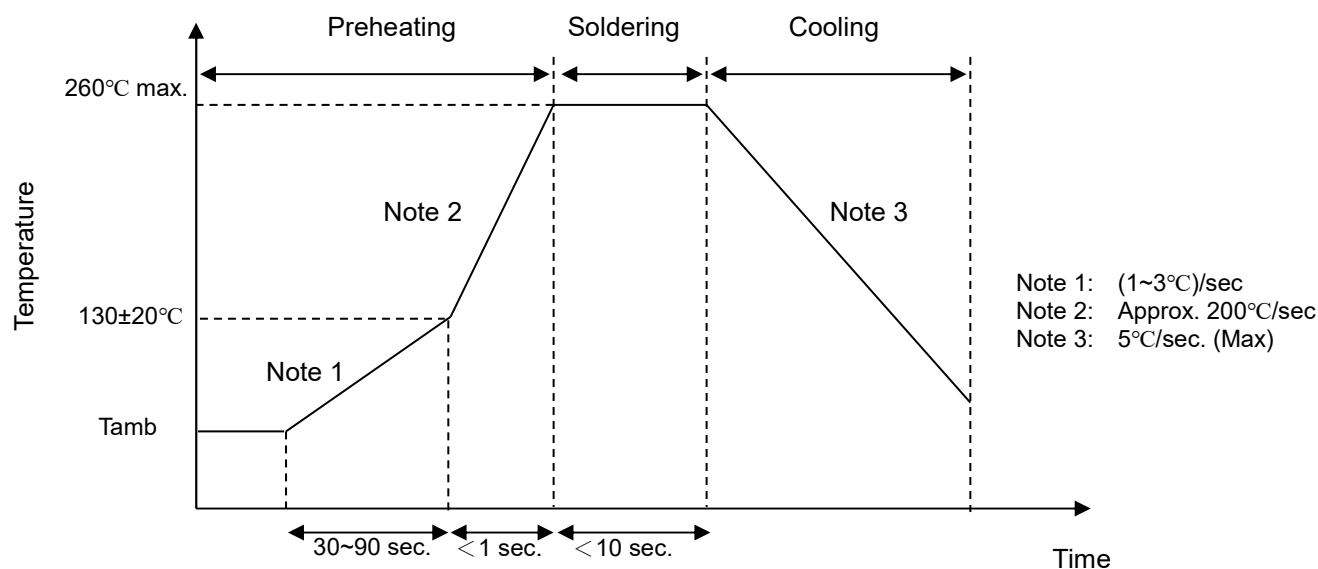

● Recommended Reworking Conditions with Soldering Iron

Item	Conditions
Temperature of Soldering Iron-tip	360°C (max.)
Soldering Time	3 sec (max.)
Distance from Varistor	2 mm (min.)

Metal Oxide Varistor : TVR-V Series



Disc Type Varistor for Surge Protection (Medium Surge Series)

■ Reliability

Item	Standard	Test conditions / Methods	Specifications															
Tensile Strength of Terminals	IEC 60068-2-21	Gradually apply the specified force and keep the unit fixed for 10±1 sec. <table style="width: 100%; border: none;"> <tr> <td style="text-align: center; border-bottom: 1px solid black;">Terminal diameter (mm)</td> <td style="text-align: center; border-bottom: 1px solid black;">Force (Kg)</td> </tr> <tr> <td style="text-align: center;">0.5<d≤0.8</td> <td style="text-align: center;">1.0</td> </tr> <tr> <td style="text-align: center;">0.8<d≤1.25</td> <td style="text-align: center;">2.0</td> </tr> </table>	Terminal diameter (mm)	Force (Kg)	0.5<d≤0.8	1.0	0.8<d≤1.25	2.0	$ \Delta V_{1mA}/V_{1mA} \leq 5\%$ No visible damage									
Terminal diameter (mm)	Force (Kg)																	
0.5<d≤0.8	1.0																	
0.8<d≤1.25	2.0																	
Bending Strength of Terminals	IEC 60068-2-21	Hold specimen and apply the force specified below to each lead. Bend the specimen to 90°, then return to the original position. Repeat the procedure in the opposite direction. <table style="width: 100%; border: none;"> <tr> <td style="text-align: center; border-bottom: 1px solid black;">Terminal diameter (mm)</td> <td style="text-align: center; border-bottom: 1px solid black;">Force (Kg)</td> </tr> <tr> <td style="text-align: center;">0.5<d≤0.8</td> <td style="text-align: center;">0.5</td> </tr> <tr> <td style="text-align: center;">0.8<d≤1.25</td> <td style="text-align: center;">1.0</td> </tr> </table>	Terminal diameter (mm)	Force (Kg)	0.5<d≤0.8	0.5	0.8<d≤1.25	1.0	$ \Delta V_{1mA}/V_{1mA} \leq 5\%$ No visible damage									
Terminal diameter (mm)	Force (Kg)																	
0.5<d≤0.8	0.5																	
0.8<d≤1.25	1.0																	
Vibration	IEC 60068-2-6	Frequency range: 10 ~ 55 Hz Amplitude: 0.75mm or 98 m/s ² Direction: 3 mutually perpendicular directions, 2 hrs each.	$ \Delta V_{1mA}/V_{1mA} \leq 5\%$ No visible damage															
Solderability	IEC 60068-2-20	245 ± 3 °C, 3 ± 0.3 sec	At least 95% of terminal electrode is covered by new solder															
Resistance to Soldering Heat	IEC 60068-2-20	260 ± 3 °C, 10 ± 1 sec	$ \Delta V_{1mA}/V_{1mA} \leq 5\%$ No visible damage															
High Temperature Storage	IEC 60068-2-2	125±2°C x 1000± 24 hrs	$ \Delta V_{1mA}/V_{1mA} \leq 5\%$ No visible damage															
Damp Heat, Steady State	IEC 60068-2-78	a. 40±2°C, 90 ~ 95 % RH, 1344 hrs b. 40±2°C, 90 ~ 95 % RH, at 10%Vdc, 1344 hrs	$ \Delta V_{1mA}/V_{1mA} \leq 5\%$ No visible damage Insulation Resistance ≥ 100MΩ															
Rapid Change of Temperature	IEC 60068-2-14	The conditions shown below shall be repeated 5 cycles <table border="1" style="width: 100%; border-collapse: collapse; text-align: center;"> <thead> <tr> <th>Step</th> <th>Temperature (°C)</th> <th>Period (minutes)</th> </tr> </thead> <tbody> <tr> <td>1</td> <td>-40±3</td> <td>30±3</td> </tr> <tr> <td>2</td> <td>Room temperature</td> <td>≤ 3</td> </tr> <tr> <td>3</td> <td>105±2</td> <td>30±3</td> </tr> <tr> <td>4</td> <td>Room temperature</td> <td>≤ 3</td> </tr> </tbody> </table>	Step	Temperature (°C)	Period (minutes)	1	-40±3	30±3	2	Room temperature	≤ 3	3	105±2	30±3	4	Room temperature	≤ 3	$ \Delta V_{1mA}/V_{1mA} \leq 5\%$ No visible damage
Step	Temperature (°C)	Period (minutes)																
1	-40±3	30±3																
2	Room temperature	≤ 3																
3	105±2	30±3																
4	Room temperature	≤ 3																
High Temp. Load	MIL-STD-202 Method 108	105±2°C, 1000±24 hrs at V _{DC} or V _{rms} (Max. Continuous Voltage)	$ \Delta V_{1mA}/V_{1mA} \leq 10\%$ No visible damage															
8/20μs Surge Life	IEC 61051-1	8/20μs waveform, 10 surge currents, unipolar, interval 30 sec, amplitude corresponding to max. surge current derating curves for 20μs.	$ \Delta V_{1mA}/V_{1mA} \leq 10\%$ No visible damage															
10/1000μs Surge Life	IEC 61051-1	Max energy, 10/1000μs waveform, test one time	$ \Delta V_{1mA}/V_{1mA} \leq 10\%$ No visible damage															
Voltage Proof	IEC 61051-1	Metal balls method, 2500 Vac 1 min	No visible damage															
Varistor Voltage Temp. Coefficient	Specification Standard	$\frac{V_{1mA \text{ at } 105^{\circ}\text{C}} - V_{1mA \text{ at } 25^{\circ}\text{C}}}{V_{1mA \text{ at } 25^{\circ}\text{C}}} \times \frac{1}{80} \times 100 (\% / ^{\circ}\text{C})$ $\frac{V_{1mA \text{ at } -40^{\circ}\text{C}} - V_{1mA \text{ at } 25^{\circ}\text{C}}}{V_{1mA \text{ at } 25^{\circ}\text{C}}} \times \frac{1}{65} \times 100 (\% / ^{\circ}\text{C})$	-0.05 ≤ TC ≤ 0.05 (%/°C)															

Metal Oxide Varistor : TVR-V Series



Disc Type Varistor for Surge Protection (Medium Surge Series)

■ Packaging

● Taping Specification

S Type (Straight lead)

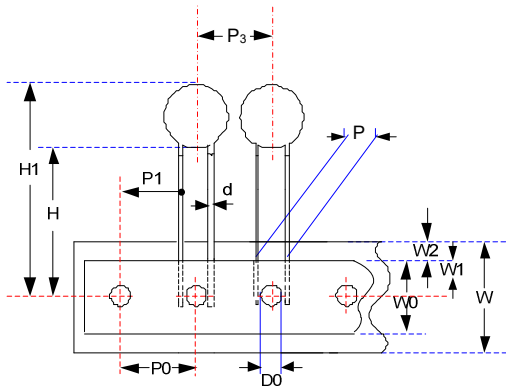

Figure A

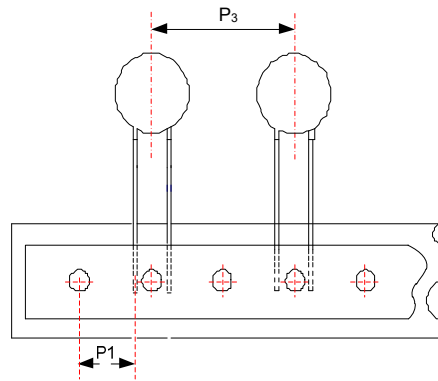

Figure B

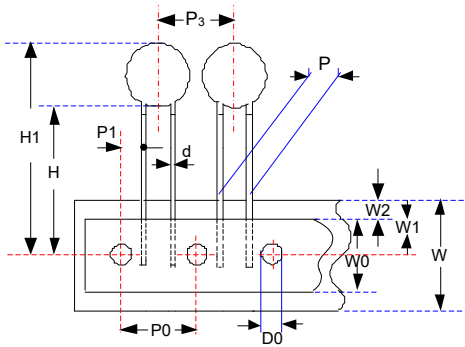
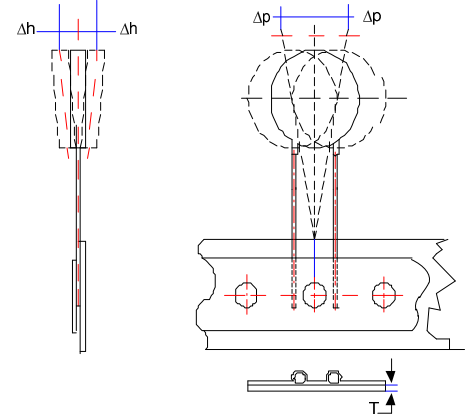

Figure C

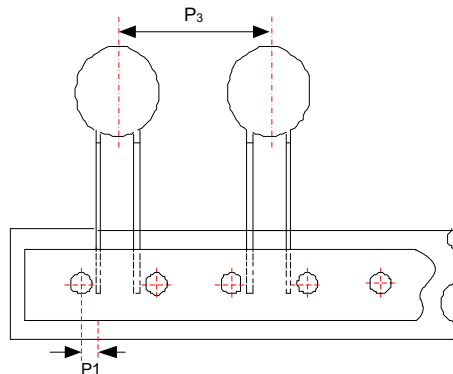

Figure D

(Unit: mm)

Taping Code	Series	P ₀	P	P ₃	P ₁	H	H ₁	d	W ₀	W ₁	W ₂	W	Δ P	Δ h	D ₀	T	Figure
		±0.3	±1	±1	±1	+2/-0	Max.	±0.02	±1	+0.75/-0.5	Max	+1/-0.5	Max.	Max.	±0.2	±0.2	
A (P ₀ :12.7)	10-V	12.7	7.5	12.7	8.55	18	33.5	0.8	12	9	3	18	1	2	4	0.6	A
	14-V	12.7	7.5	25.4	8.55	18	38.0	0.8	12	9	3	18	1	2	4	0.6	B
E (P ₀ :15.0)	10-V	15	7.5	15.0	3.35	18	33.5	0.8	12	9	3	18	1	2	4	0.6	C
	14-V	15	7.5	30.0	3.35	18	38.0	0.8	12	9	3	18	1	2	4	0.6	D

Metal Oxide Varistor : TVR-V Series



Disc Type Varistor for Surge Protection (Medium Surge Series)

F Type (Y kink lead)

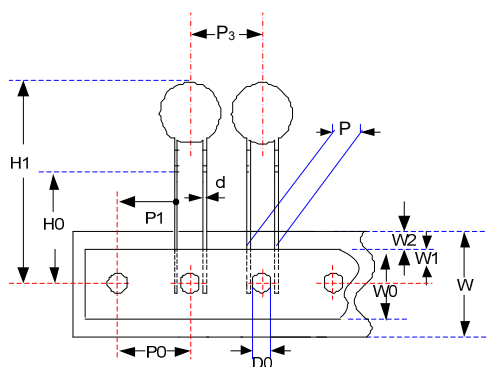

Figure A

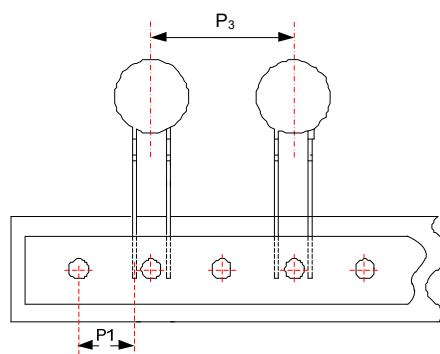

Figure B

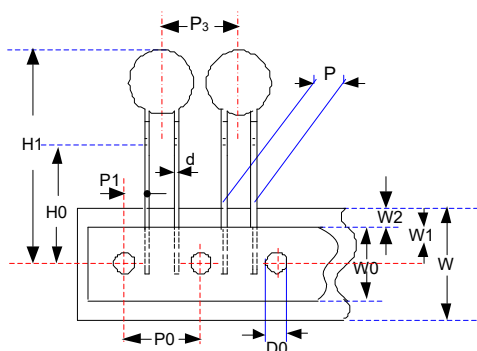
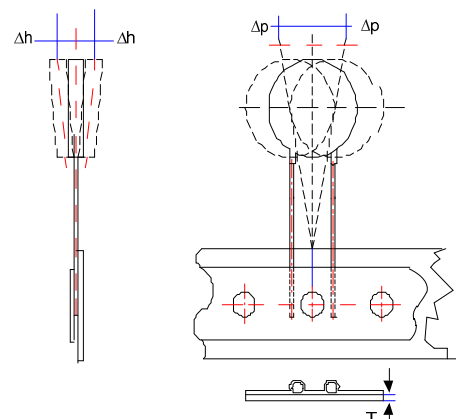

Figure C

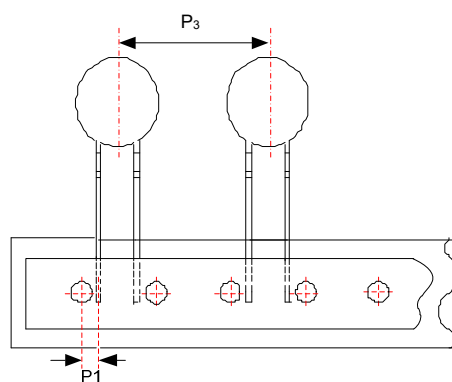

Figure D

(Unit: mm)

Taping Code	Series	P ₀	P	P ₃	P ₁	H ₀	H ₁	d	W ₀	W ₁	W ₂	W	Δ P	Δ h	D ₀	T	Figure
		±0.3	±1	±1	±1	±0.5	Max.	±0.02	±1	+0.75/ -0.5	Max	+1/ -0.5	Max.	Max.	±0.2	±0.2	
A (P ₀ :12.7)	10-V	12.7	7.5	12.7	8.55	16	33.5	0.8	12	9	3	18	1	2	4	0.6	A
	14-V	12.7	7.5	25.4	8.55	16	38.0	0.8	12	9	3	18	1	2	4	0.6	B
E (P ₀ :15.0)	10-V	15.0	7.5	15.0	3.35	16	33.5	0.8	12	9	3	18	1	2	4	0.6	C
	14-V	15.0	7.5	30.0	3.35	16	38.0	0.8	12	9	3	18	1	2	4	0.6	D

Metal Oxide Varistor : TVR-V Series



Disc Type Varistor for Surge Protection (Medium Surge Series)

■ Quantity

● Bulk Packing

Series	Quantity (pcs/bag)
TVR10-V (201~751)	200
TVR10-V (781~112)	100
TVR14-V	100

● Reel Packing

Series	A (mm)	Quantity (pcs/reel)
TVR10(201~911)-V	46	1,000
TVR10(102~112)-V		750
TVR14(201~391)-V		750
TVR14(431~112)-V		500

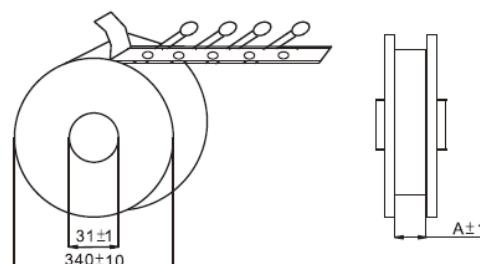

(Unit: mm)

● Ammo Packing

Series	Quantity (pcs/box) P0=12.7mm	Quantity (pcs/box) P0=15.0mm
TVR10(201~361)-V	1,100	850
TVR10(391~621)-V	800	650
TVR10(681~112)-V	700	600
TVR14(201~241)-V	700	550
TVR14271-V	600	400
TVR14(301~561)-V	500	400
TVR14(621~751)-V	400	300
TVR14(821~112)-V	300	250

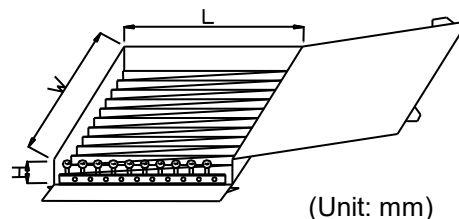

(Unit: mm)

Series	W±5	L±5	H±5
TVR10-V & TVR14-V	345	275	55

■ Warehouse Storage Conditions of Products

● Storage Conditions:

1. Storage Temperature: $-10^{\circ}\text{C} \sim +40^{\circ}\text{C}$
2. Relative Humidity: $\leq 75\% \text{RH}$
3. Keep away from corrosive atmosphere and sunlight.

● Period of Storage: 1 year